

洛阳恒昌重工有限公司

Luoyang Hengchang Heavy Machinery CO.,Ltd

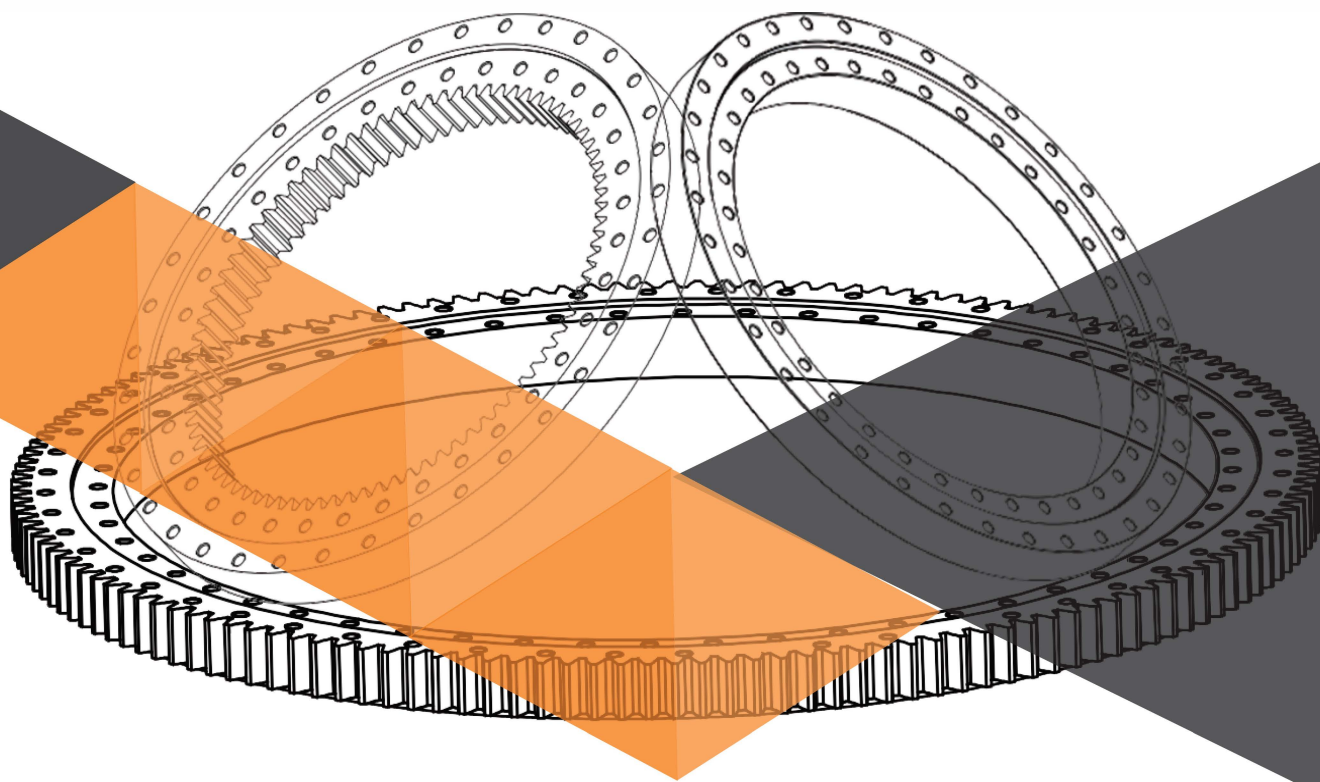

回转支承 | 转盘轴承 | 精密轴承
Slewing bearing | Slewing ring | Precision bearing

目录

Contents

公司简介	
Company profile	1
企业文化	
Enterprise culture	2
工艺流程	
Process flow	3
回转支承类型和系列一	
Types and series one of slewing bearings	8
单排四点接触球式回转支承 (01 系列)	
Single row four point contact ball slewing bearing (01 Series)	9
单排交叉滚柱式回转支承 (11 系列)	
Single row cross roller slewing bearing (11 Series)	15
双排球式回转支承 (02 系列)	
Double row ball slewing bearing (02 Series)	19
三排滚柱式回转支承 (13 系列)	
Three row roller slewing bearing (13 Series)	23
回转支承类型和系列二	
Types and series two of slewing bearings	28
单排交叉滚柱式回转支承 (HJ 系列)	
Single row cross roller slewing bearing (HJ Series)	29
单排四点接触球回转支承 (HS 系列)	
Single row four point contact ball slewing bearing (HS Series)	31
回转支承类型和系列三	
Types and series three of slewing bearings	33
单排四点接触球回转支承 (Q 系列)	
Single row four point contact ball slewing bearing (Q Series)	34
回转支承类型和系列四	
Types and series four of slewing bearings	38
单排交叉滚柱式回转支承 (797 系列)	
Single row cross roller slewing bearing (797 Series)	39
轴承的安装与保养	
Bearing installation and maintenance	43
应用领域	
Application field	52
选型信息表	
Model selection information table	53

公司简介

Company profile

洛阳恒昌重工有限公司，坐落于美丽的牡丹花城、有“轴承之乡”美誉的十三朝古都——洛阳。是一家集专业设计、研发、生产、销售及服务于一体的回转支承/转盘轴承综合型实体企业。依托于洛阳专业轴承加工基地优势，经过蓬勃发展，公司凝聚了一批经验丰富的轴承设计人员和技术娴熟的一线生产工人，配合先进的生产加工设备及检测工具，从根源上保证了产品的质量及技术服务。

我公司主要生产直径 20-10000mm 的回转支承 / 转盘轴承及各种高精密轴承、大型推力球轴承、非标机械件等产品，精度涵盖 P0、P6、P5、P4 四个等级，产品类型包括单排四点接触球结构、交叉圆柱滚子结构、三排圆柱滚子结构、双排球结构、球柱联合结构、薄壁法兰结构、大型推力球结构等。产品广泛应用于新能源、医疗、游乐、自动化、起重，建筑、矿山、冶金、港口、纺织、船舶、环保、航空航天、风力发电等领域。公司产品销往全国各地并出口欧洲、美洲、亚洲等多个国家和地区，得到广大用户的赞同和认可。

公司一贯坚持“以人为本、客户至上、技术创新、品质求精”的价值理念；以“务实、创新、团结、高效”的企业开拓精神；一切以客户需求为中心，对不同的客户实行个性化优化设计及定制化柔性生产，来满足客户的精准需求，力求客户得到高性价比的产品和服务，以实现客我双方互利共赢的

长期发展战略目标。恒昌重工“智”造未来，我们只做优质产品和服务的提供者！

Luoyang Hengchang Heavy Machinery CO.,Ltd. is located in the beautiful Peony Flower City, known as the “Bearing Town” of China’s thirteenth ancient capital - Luoyang. It is a comprehensive entity enterprise integrating professional design, research and development, manufacturing, sales and service of slewing rings and slewing bearings. Relying on the advantages of Luoyang professional bearing processing base, after vigorous development, the company has gathered a group of experienced bearing designers and skilled front-line production workers, with advanced production and processing equipment and testing tools, to ensure the quality of products from the root and technical services.

Our company mainly produces 20-10000mm diameter slewing bearing and various high precision slewing bearings, large thrust ball bearings, non-standard special-shaped bearings and other products, The accuracy covers P 0, P 6, P 5, P 4 four grades, product types include single row four-point contact ball structure, cross cylindrical roller structure, three row cylindrical roller structure. Double row ball structure, ball and roller combination structure, thin-wall flange structure, large thrust ball structure, etc. Products are widely used in new energy, medical, recreation, automation, lifting, construction, mining, metallurgy, port, textile, shipping, environmental protection, aerospace, wind power and other fields. The company’s products are sold all over the country and exported to Europe, America, Asia and other countries and regions, and have won the approval and recognition of the vast number of users.

The company has always adhered to the value concept of “people-oriented, customer-oriented, technological innovation, quality improvement”, “pragmatic, innovative, united, efficient” enterprise pioneering spirit; the customer all needs as the center, to implement personalized optimization design and customized flexible production for different customers to meet the precise needs of customers. In order to achieve the long-term development strategic goal of mutual benefit and win-win between customers and us, we strive to provide customers with high cost-effective products and services. Hengchang Heavy Machinery, “wisdom” to build the future, we only do high-quality products and professional service provider!

企业文化 Enterprise culture

愿 景： 打造中国优质轴承制造者和产品方案提供者；

使 命： 为员工搭建实现梦想的平台，为客户提供实现价值的产品；

精 神： 务实，创新，团结，高效；

价 值 观： 以人为本、客户至上、技术创新、品质求精、团队合作、尊重员工、分享成果；

服务承诺： 免费提供售前、售中、售后技术咨询服务，一次合作，终生朋友！

Vision : Build up China's high quality bearing manufacturer and product solution provider;

Mission: To build a platform for employees to realize their dreams, to provide customers with products to realize their values;

Spirit : Pragmatic, Innovative, United and Efficient.

Values : People-oriented, Customer-oriented, Technological innovation, Quality improvement, Teamwork, Respect for employees, Sharing results;

Service commitment :
Free pre-sale, in-sale and after-sale technical advisory services. A cooperation, lifelong friends!

质量控制 Quality Control

我公司2022年通过了ISO9001质量体系认证，并执行JB/T2003-2011标准及相应的国家标准。公司拥有齐全的检测设备和先进的检测方法。在产品生产过程中，严格执行全工序检验流程，确保每一套出厂的产品都是合格品。近三年来，我们的产品检验合格率超过了98%，客户投诉率低于0.6%高质量的产品和优质专业的服务，得到国内外客户的一致认可与好评！我们一贯坚持的信念就是打造中国优质轴承制造者和产品方案的提供者！让全世界都爱上中国造！

Our company has passed the ISO 9001 quality system certification in 2022, and follow the JB/T 2003-2011 Standard and the Corresponding National Standards. The company has quality testing equipment with advanced testing methods in every step. In the production process of products, strict implementation of the whole process inspection to ensure that each set of products are qualified. Over the past three years, our product pass rate has exceeded 98%, customer complaint rate is less than 0.6%. High quality products and professional services have won unanimously recognized and praised by domestic and foreign customers! We have always held the belief that is to be China's high-quality bearings manufacturer and product solutions provider! To make world love "made in China"!

工艺流程 Process flow

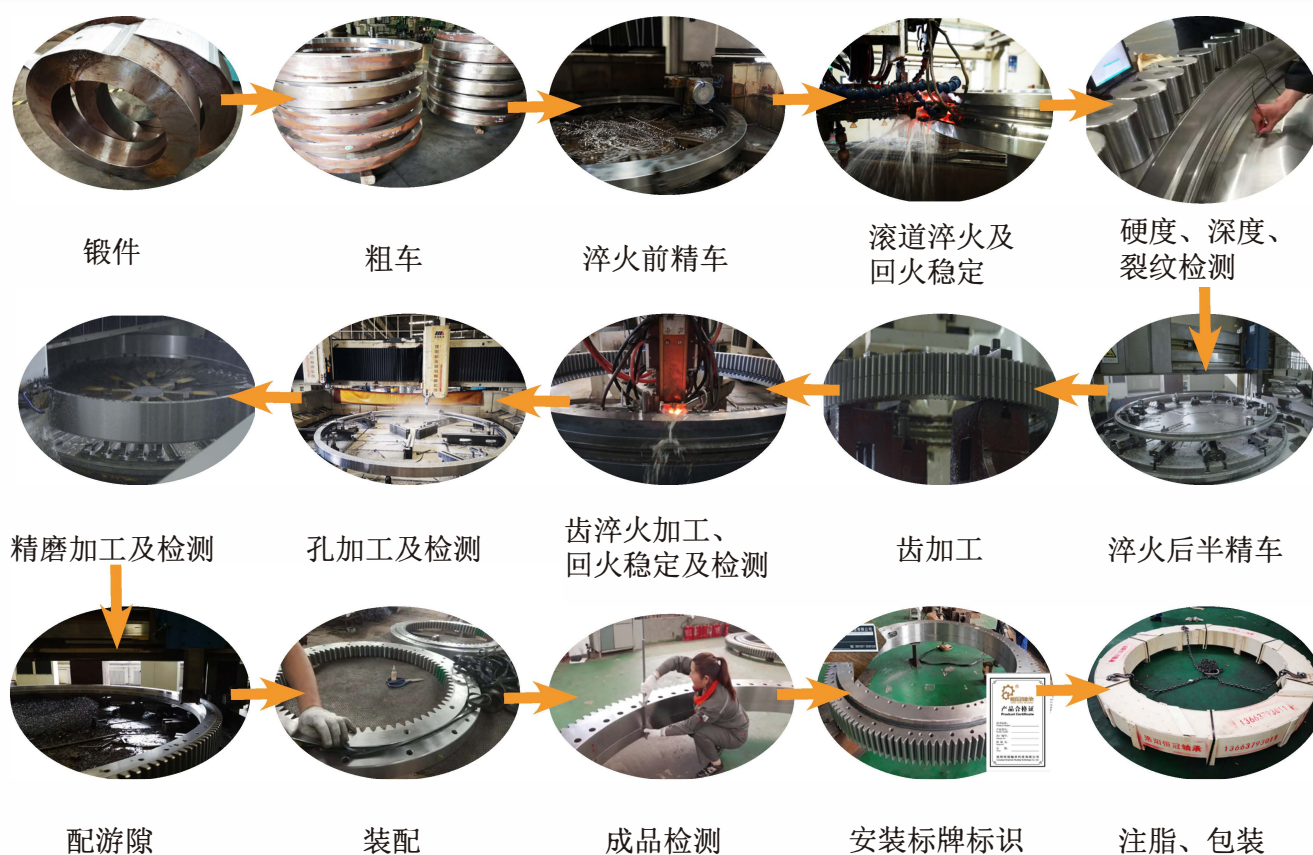

一、锻件

Forgings

1. 实地考察，选择优质供应商，对其原材料进行取样化验并在后续合作中不定时进行抽检，以保证原材料符合国家标准，机械性能满足产品设计要求。
2. 锻件进厂后，由质检人员进行外观查看及外形尺寸测量，确保无明显缺陷，同时有足够的余量加工至成品。

1. Select top suppliers, sampling and testing of their raw materials in random to make sure that raw material meets national standards and mechanical properties meet product design requirements.
2. After the forgings enter the factory, the quality inspectors will perform the appearance inspection and the dimensional measurement to ensure that there are no obvious defects, and keep enough margin to process the finished products.

二、粗车

Rough turning

1. 去氧化皮粗车，根据成品尺寸大小，预留不同的尺寸余量。
2. 超声波探伤，对粗车后的锻件进行超声波探伤，检测材料内部是否有气孔、夹渣、叠层等缺陷。
3. 调质处理，根据国标或客户特殊要求，对粗车后的锻件进行调质处理，整体提升机械性能。
4. 调质硬度检测，根据调质硬度要求检测锻件整体硬度是否合格。

1. Descaling rough turning: according to the size of finished products, reserve enough size margins.
2. Ultrasound flaw detection: the forgings after rough turning are detected by ultrasound, whether there are any defects in the material: such as blowhole, slag inclusion, lamination and so on.
3. Tempering treatment: according to the national standard or the special requirements of customers, the tempering treatment could improve the mechanical properties.
4. Hardness testing of tempering treatment: testing whether the overall hardness of forgings is qualified according to quenching and tempering hardness requirements.

三、淬火前精车

Precision turning before quenching

将滚道精车成型，根据不同的滚道结构类型及尺寸大小，预留不同的尺寸余量，保证机加变形和淬火变形可以消除，同时又需保证余量尽可能小。

According to the type and size of the raceway structure, a sufficient margin is reserved to ensure that the machine deformation and quenching deformation can be eliminated, and try to remaining amount is required to be as small as possible.

四、滚道淬火及回火稳定

Quenching and temper stability of raceway

采用中频淬火工艺，对滚道进行淬火加工，淬火区域硬度达到 HRC55-62，有效深度不低于 3mm 淬火后进行回火稳定处理，消除淬火应力，减少后续加工变形并降低滚道开裂风险。

The raceway is quenched by medium frequency quenching process. The hardness of quenching area reaches HRC55-62, and the effective depth is not less than 3 mm. After quenching, the raceway is tempered stably to eliminate quenching stress, reduce subsequent processing deformation and reduce the risk of raceway cracking.

五、硬度、深度、裂纹检测

Detection of hardness, depth and crack

对淬火区域进行硬度、有效深度及裂纹的检测，特别是起始位置

Detection of hardness, effective depth and crack in quenched area, especially initial position.

六、淬火后半精车

Quenched semi-finish turning

加工基准面，为后续齿、孔等工序加工提供基准

Processing datum level, providing datum for subsequent processing of teeth, holes, etc.

七、齿加工

Tooth processing

根据不同类别的齿形，可以选择插齿、滚齿、铣齿等加工方法，精度等级可以满足 7-10 级，如需更高精度，采用磨齿，可以满足 4-6 级

According to different kinds of tooth shape, processing methods such as shaping, hobbing and milling can be selected. The accuracy level can meet 7-10 grades. If higher accuracy is needed, grinding can meet 4-6 grades.

八、齿淬火加工、回火稳定及检测

Hardening, tempering stability and testing of teeth

为满足齿强度及使用寿命，根据不同需求对齿面、齿根、齿顶部位进行高频淬火，硬度可满足 HRC40-55，深度可满足 1.5mm，淬火后进行回火稳定处理，消除淬火应力，降低淬火部位开裂风险，稳定结束进行硬度及裂纹检测

In order to meet the strength and service life of the teeth, high frequency quenching is carried out on the tooth surface, root and top according to different requirements. The hardness can meet HRC 40-55 and the depth can meet 1.5mm. Tempering stabilization after quenching, the quenching stress can be eliminated, the cracking risk of the quenched part can be reduced, and the hardness and crack detection can be carried out after quenching.

九、孔加工及检测

Hole processing and detection

加工过程中控制弦长、壁厚、孔径等项目并及时修正，对于精度要求高的螺纹进行通止规检验

Control the chord length, wall thickness, aperture and other items in the machining process and correct them in time. Inspection for threads with high accuracy requirements.

十、精磨加工及检测

Fine grinding and testing

对于高精度的产品，采用精磨加工，有效控制套圈椭圆、壁厚、平面度等参数，以保证成品精度满足标准或客户图纸要求

For high-precision products, precise grinding is used to effectively control the parameters of ring ellipse, wall thickness and flatness, so as to ensure that the precision of finished products meets the requirements of standards or customer drawings.

十一、配游隙

Match clearance

精准测量零件尺寸，计算零件余量，根据图纸要求试配游隙

Accurate measurement of part size, Calculating spare parts allowance, according to the requirements of the drawings to match clearance.

十二、装配

Assembling

去除套圈毛刺、清洗干净，严格按照总装图纸要求，安装相应尺寸及数量的滚动体、保持架、密封等附件，转动检测是否回转灵活及有无异响

Remove ring burrs and clean up. Install corresponding size and number of rollers, cages, seals and other accessories in strict accordance with the requirements of assembly drawings. Rotate to detect whether the rotation is flexible and whether there is any abnormal noise.

十三、成品检测

Finished product testing

装配完成，对各技术指标进行检测并做详细记录

The assembly is completed, detecting whether all aspects meet technical standards

十四、安装标牌标识

Installation of sign mar

根据客户要求，安装标牌标识

Install sign and logo according to customer requirement

十五、注脂、包装

Fill grease and packaging

1. 产品包装前，根据客户要求加注相应牌号、品型的润滑脂，保护滚道防止损伤

2. 采用出口免熏蒸木箱，适合长途海运，以满足不同运输距离、存放时间及地域的安全到货

1. Before product packaging, add corresponding brand and type grease according to customer's requirements to protect raceway from damage.

2. Export wooden boxes suitable for sea transportation are used to ensure the safe arrival of goods at different transportation distances, storage times and regions.

常用结构 Common Structure

回转支承也称转盘轴承，多属于大型轴承，尺寸大、精度高、结构紧凑，常在低速重载条件下工作，能同时承受轴向、径向及倾覆力矩等负荷，洛阳恒冠轴承可以研制外径 0.2-10 米尺寸范围的回转支承。

Slewing bearings are mostly large bearings, with large size, high precision and compact structure, working under heavy load at low speed, it can bearing axial, radial and tilting moment and etc, LYHGB can research and develop outer dia 0.2-10M slewing bearings.

常用结构形式

四点接触球式回转支承（图 1-1）；
双排球式回转支承（图 1-2）；
交叉圆柱滚子式回转支承（图 1-3）；
三排圆柱滚子式回转支承（图 1-4）；

Common Structure:

Four point contact ball slewing bearings(Picture1-1);
Double-row ball slewing bearings(Picture1-2);
Cross cylindrical roller slewing bearings(Picture1-3);
Three-row cylindrical roller combined slewing bearings(Picture1-4)



（图 1-1）

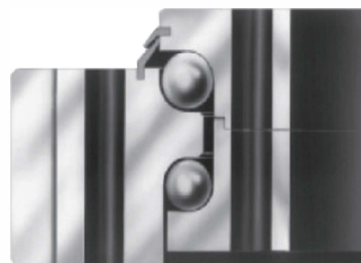

（图 1-2）

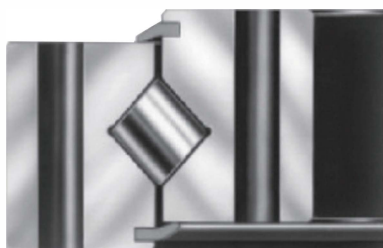

（图 1-3）



（图 1-4）

回转支承类型和系列一 Types and series one of slewing bearings

《JB/T2300-2011》标准回转支承编号方法：

《JB/T2300-2011》standard slewing bearing numbering method

XX	X	XX	XXXX
--	-	--	----
(1)	(2)	(3)	(4)

(1) 结构型式：

- 01- 四点接触球式回转支承
- 02- 双排球式回转支承
- 11- 单排交叉滚子式回转支承
- 13- 三排圆柱滚子组合回转支承

(2) 传动方式

- 0- 无齿式
- 1- 渐开线圆柱齿轮外啮合小模数
- 2- 渐开线圆柱齿轮外啮合大模数
- 3- 渐开线圆柱齿轮内啮合小模数
- 4- 渐开线圆柱齿轮内啮合大模数

(3) 滚动体（钢球或者滚柱）直径

(4) 滚道中心圆直径

(1) The types of products

- 01-Single row four point contact ball slewing bearing
- 02-Double Row Ball slewing bearing
- 11-Single row cross roller slewing bearing
- 13-Three row roller slewing bearing

(2) Meshing mode

- 0-No gear type
- 1-External gear small module
- 2-External gear large module
- 3-Internal gear small module
- 4-Internal gear large module

(3) Diameter of rolling body (steel ball or cylindrical roller)

(4) Raceway center diameter

基本型号规格举例

The examples of basic models and specifications

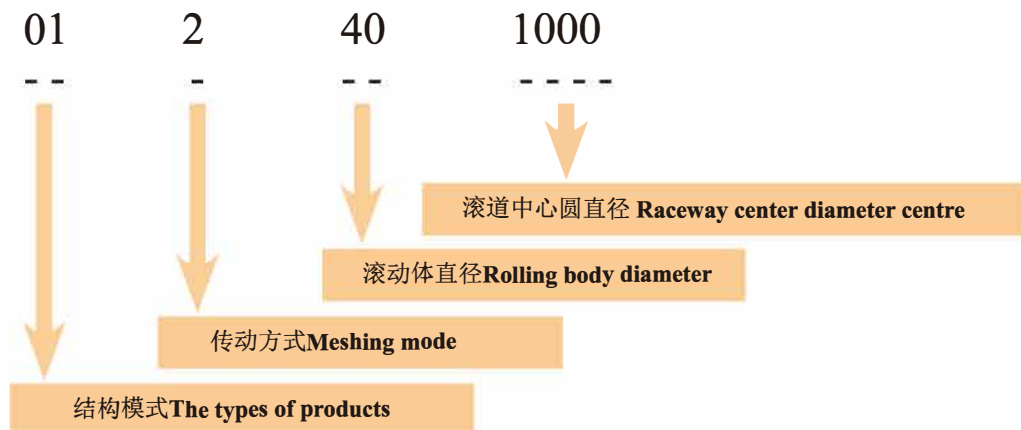

因此：该型号规格表示为单排四点接触球外齿式（大模数）回转支承，钢球直径 40mm，滚道中心圆直径 1000mm

Therefore, the specifications of this type are expressed as single row four-point contact ball external gear (large modulus) slewing bearing, steel ball diameter 40mm, raceway center diameter 1000mm

01 系列

单排四点接触球式回转支承 (01 系列)

Single row four point contact ball slewing bearing (01 Series)

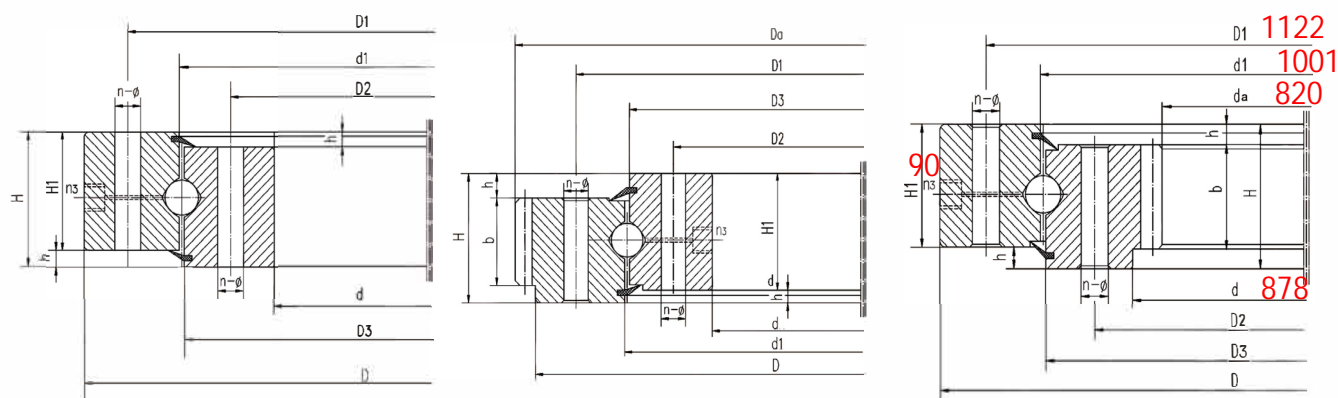

无齿
Non Gear

外齿
External Gear

内齿
Internal Gear

结构特点、性能、适用范围

单排四点接触球式回转支承由两个座圈组成，结构紧凑、重量轻、钢球与圆弧滚道四点接触，能同时承受轴向力、径向力和倾翻力矩。回转式输送机、焊接操作机、中小型起重机和挖掘机等工程机械均可选用。

Structural characteristics, performance and scope of application

The single row four-point contact ball slewing bearing is composed of two seat rings. It has compact structure, light weight, and four-point contact between steel ball and arc raceway. It can bear axial force, radial force and overturning moment at the same time. The construction machinery of rotary conveyor, welding manipulator, small and medium-sized crane and excavator can be selected.

轴承型号 Bearing type			外形尺寸 Boundary dimensions			安装孔尺寸 Mounting hole diameter				结构尺寸 Structure dimensions					齿轮参数 Gear parameters						质量 Mass kg	
无齿式 Non-gear type	外齿式 External gear type	内齿式 Internal gear type	D	d	H	D1	D2	n	φ	D3	d1	H1	h	n3	m	外齿式 Ext gear		内齿式 Int gear		b		x
			mm			mm			mm	mm			Da mm			Z	da mm	Z	mm			
010.20.200	011.20.200	—	280	120	60	248	152	12	16	199	201	50	10	2/M6X1	3	300	98	—	—	40	0	20
010.20.224	011.20.224	—	304	144	60	272	176	12	16	223	225	50	10	2/M6X1	3	321	105	—	—	40	0	22
010.20.250	011.20.250	—	330	170	60	298	202	18	16	249	251	50	10	2/M6X1	4	352	86	—	—	40	0	25
010.20.280	011.20.280	—	360	200	60	328	232	18	16	279	281	50	10	2/M6X1	4	348	94	—	—	40	0	28
010.25.315	011.25.315	013.25.315	408	222	70	372	258	20	18	314	316	60	10	2/M8X1	5	435	85	190	40	50	0	43
010.25.355	011.25.355	013.25.355	448	262	70	412	298	20	18	354	356	60	10	2/M8X1	5	475	93	235	49	50	0	49
010.25.400	011.25.400	013.25.400	493	307	70	457	343	20	18	399	401	60	10	2/M8X1	6	528	86	276	48	50	0	55
010.25.450	011.25.450	013.25.450	543	357	70	507	393	20	18	449	451	60	10	2/M8X1	6	576	94	324	56	50	0	64
010.30.500	011.30.500	013.30.500	602	398	80	566	434	20	18	498	501	70	10	4/M10X1	5	630	123	365	74	60	+0.5	75.8
	012.30.500	014.30.500													6	630	102	366	62	60	+0.5	75.8
010.30.560	011.30.560	013.30.560	662	458	80	626	494	20	18	558	561	70	10	4/M10X1	5	690	135	425	86	60	+0.5	94
	012.30.560	014.30.560													6	690	112	426	72	60	+0.5	94
010.30.630	011.30.630	013.30.630	732	528	80	696	564	24	18	628	631	70	10	4/M10X1	6	774	126	492	83	60	+0.5	110
	012.30.630	014.30.630													8	776	94	488	62	60	+0.5	110
010.30.710	011.30.710	013.30.710	812	608	80	776	664	24	18	708	711	70	10	4/M10X1	6	852	139	570	96	60	+0.5	120
	012.30.710	014.30.710													8	856	104	568	72	60	+0.5	120
010.40.800	011.40.800	013.40.800	922	678	100	878	722	30	22	798	801	90	10	6/M10X1	8	968	118	632	80	80	+0.5	220
	012.40.800	014.40.800													10	970	94	630	64	80	+0.5	220
010.40.900	011.40.900	013.40.900	1022	778	100	978	822	30	22	898	901	90	10	6/M10X1	8	1064	130	736	93	80	+0.5	240
	012.40.900	014.40.900													10	1070	104	730	74	80	+0.5	240
010.40.1000	011.40.1000	013.40.1000	1122	878	100	1078	922	36	22	998	1001	90	10	6/M10X1	10	1190	116	820	83	80	+0.5	270
	012.40.1000	014.40.1000													12	1188	96	816	69	80	+0.5	270
010.40.1120	011.40.1120	013.40.1120	1242	998	100	1198	1042	36	22	1118	1121	90	10	6/M10X1	10	1300	127	940	95	80	+0.5	300
	012.40.1120	014.40.1120													12	1308	106	936	79	80	+0.5	300
010.45.1250	011.45.1250	013.45.1250	1390	1110	110	1337	1163	40	26	1248	1252	100	10	6/M10X1	12	1452	118	1044	88	90	+0.5	420
	012.45.1250	014.45.1250													14	1456	101	1036	75	90	+0.5	420
010.45.1400	011.45.1400	013.45.1400	1540	1260	110	1487	1313	40	26	1398	1402	100	10	6/M10X1	12	1608	131	1188	100	90	+0.5	480
	012.45.1400	014.45.1400													14	1610	112	1190	86	90	+0.5	480
010.45.1600	011.45.1600	013.45.1600	1740	1460	110	1687	1513	45	26	1598	1602	100	10	8/M10X1	14	1820	127	1386	100	90	+0.5	550
	012.45.1600	014.45.1600													16	1824	111	1376	87	90	+0.5	550

轴承型号 Bearing type			外形尺寸 Boundary dimensions			安装孔尺寸 Mounting hole diameter				结构尺寸 Structure dimensions				齿轮参数 Gear parameters						质量 Mass kg		
无齿式 Non-gear type	外齿式 External gear type	内齿式 Internal gear type	D	d	H	D1	D2	n	φ	D3	d1	H1	h	n3	m	外齿式 Ext gear		内齿式 Int gear			b	x
			mm			mm			mm	mm			mm			mm	Z	da mm	Z		mm	
010.45.1800	011.45.1800	013.45.1800	1940	1660	110	1887	1713	45	26	1802	1798	100	10	8/M10X1	14	2016	141	1568	113	90	+0.5	610
	012.45.1800	014.45.1800													16	2016	123	1568	99	90	+0.5	610
010.60.2000	011.60.2000	013.60.2000	2178	1825	144	2110	1891	48	33	2002	1998	132	12	8/M10X1	16	2272	139	1728	109	120	+0.5	1100
	012.60.2000	014.60.2000													18	2268	123	1728	97	120	+0.5	1100
010.60.2240	011.60.2240	013.60.2240	2418	2065	144	2350	2131	48	33	2242	2238	132	12	8/M10X1	16	2496	153	1984	125	120	+0.5	1250
	012.60.2240	014.60.2240													18	2502	136	1980	111	120	+0.5	1250
010.60.2500	011.60.2500	013.60.2500	2678	2325	144	2610	2391	56	33	2502	2498	132	12	8/M10X1	18	2772	151	2232	125	120	+0.5	1400
	012.60.2500	014.60.2500													20	2780	136	2220	112	120	+0.5	1400
010.60.2800	011.60.2800	013.60.2800	2978	2625	144	2910	2691	56	33	2802	2798	132	12	8/M10X1	18	3078	168	2520	141	120	+0.5	1600
	012.60.2800	014.60.2800													20	3080	151	2520	141	120	+0.5	1600
010.75.3150	011.75.3150	013.75.3150	3376	2922	174	3286	3014	56	45	3152	3147	162	12	8/M10X1	20	3480	171	2820	142	150	+0.5	2800
	012.75.3150	014.75.3150													22	3476	115	2816	129	150	+0.5	2800
010.75.3550	011.75.3550	013.75.3550	3776	3322	174	3686	3414	56	45	3552	3547	162	12	8/M10X1	20	3880	191	3220	162	150	+0.5	3200
	012.75.3550	014.75.3550													22	3894	174	3212	147	150	+0.5	3200
010.75.4000	011.75.4000	013.75.4000	4226	3772	174	4136	3864	60	45	4002	3997	162	12	10/M10X1	22	4334	194	3652	167	150	+0.5	3600
	012.75.4000	014.75.4000													25	4350	171	3650	147	150	+0.5	3600
010.75.4500	011.75.4500	013.75.4500	4726	4272	174	4636	4364	60	45	4502	4497	162	12	10/M10X1	22	4840	271	4158	190	150	+0.5	4000
	012.75.4500	014.75.4500													25	4850	191	4150	167	150	+0.5	4000

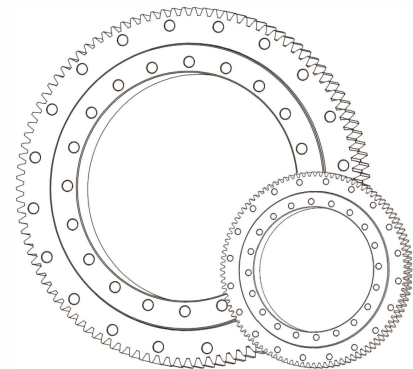

01 系列负载曲线图

Series 01 Load Chart

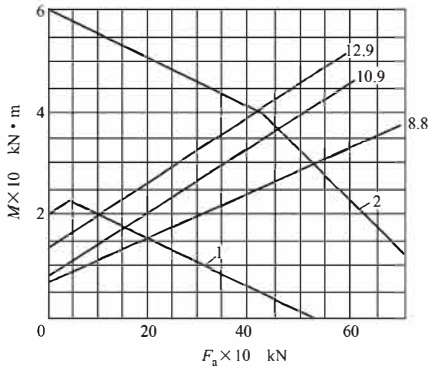

01*. 20. 200

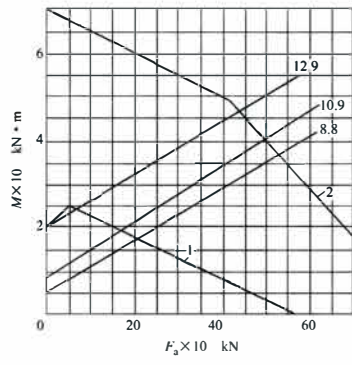

01*. 20. 224

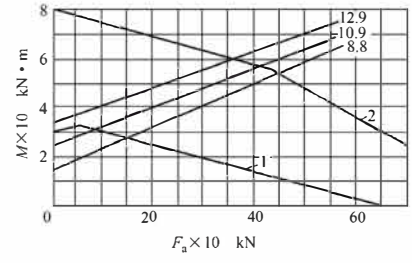

01*. 20. 250

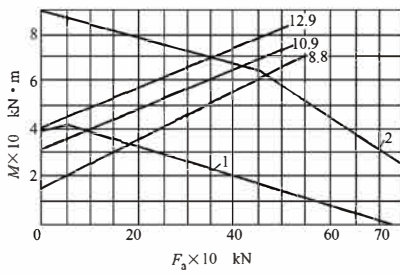

01*. 20. 280

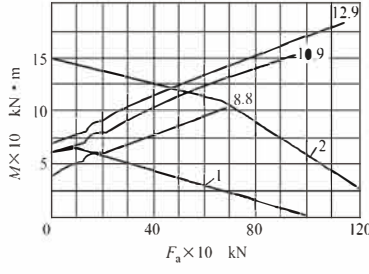

01*. 25. 315

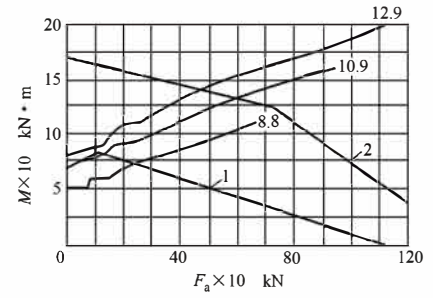

01*. 25. 355

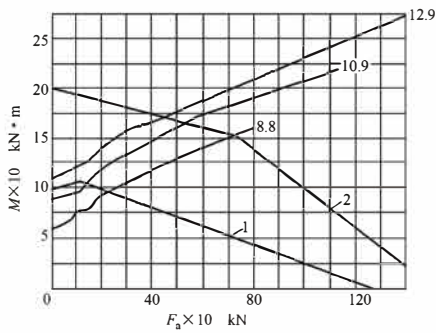

01*. 20. 400

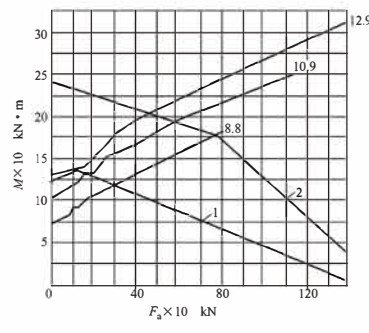

01*. 25. 450

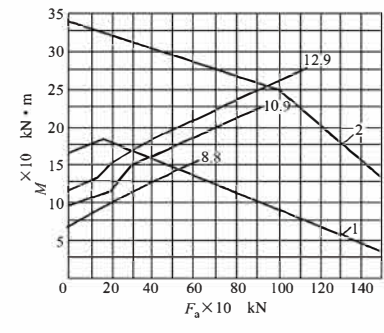

01*. 30. 500

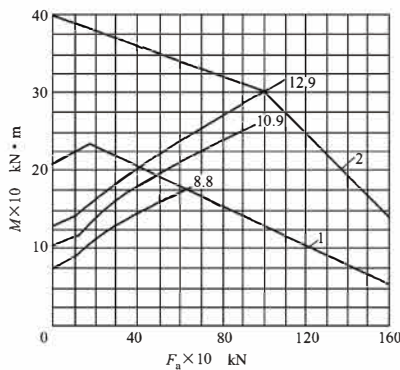

01*. 30. 560

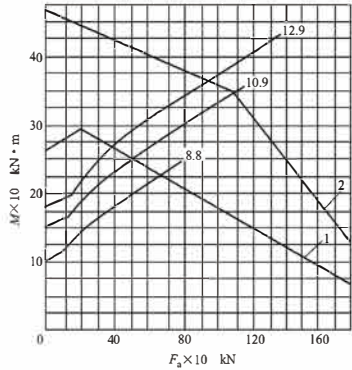

01*. 30. 630

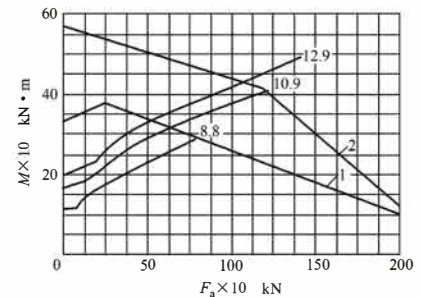

01*. 30. 710

01 系列负载曲线图

Series 01 Load Chart

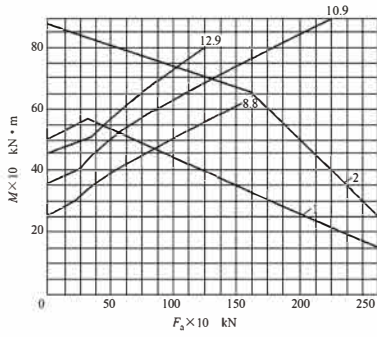

01*. 40. 800

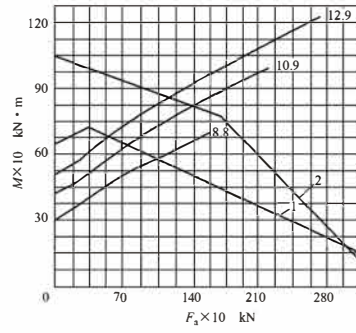

01*. 40. 900

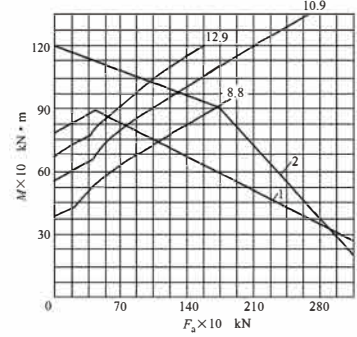

01*. 40. 1000

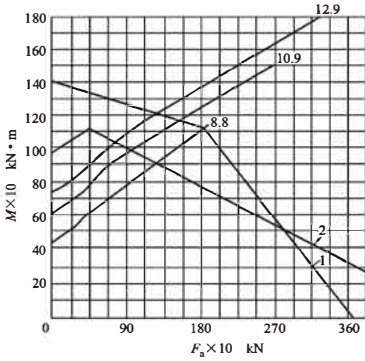

01*. 40. 1120

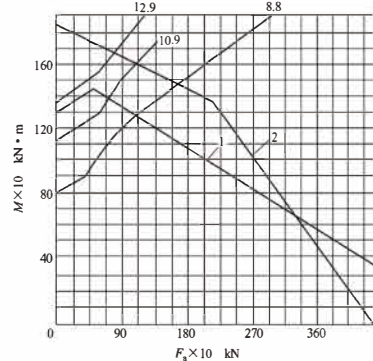

01*. 45. 1250

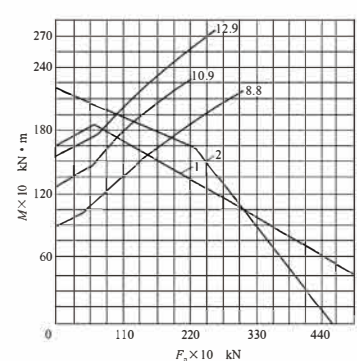

01*. 45. 1400

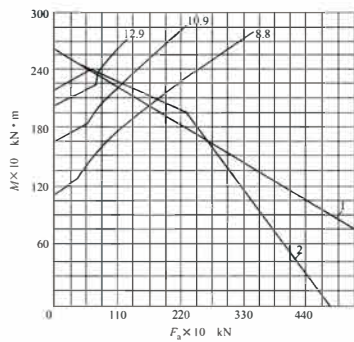

01*. 45. 1600

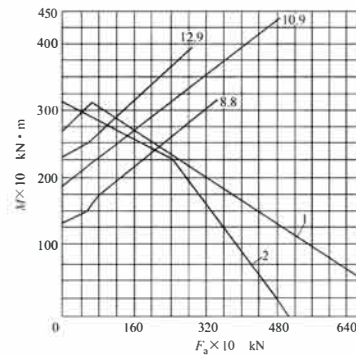

01*. 45. 1800

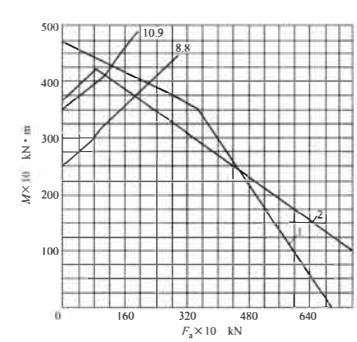

01*. 60. 2000

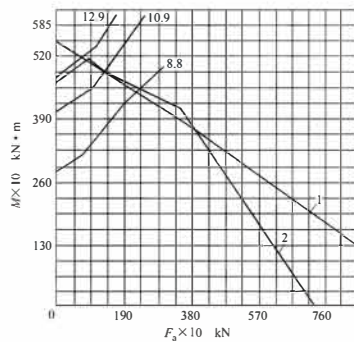

01*. 60. 2240

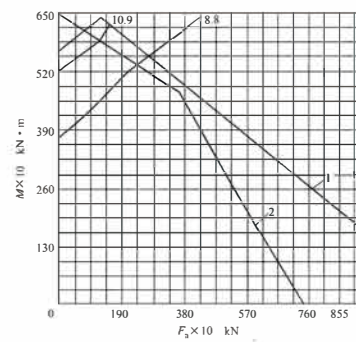

01*. 60. 2500

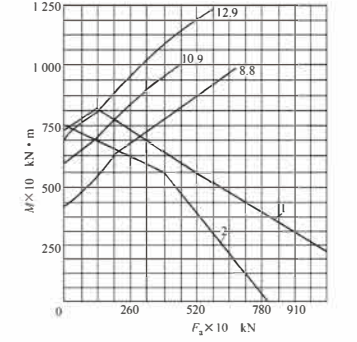

01*. 60. 2800

01 系列负载曲线图 Series 01 Load Chart

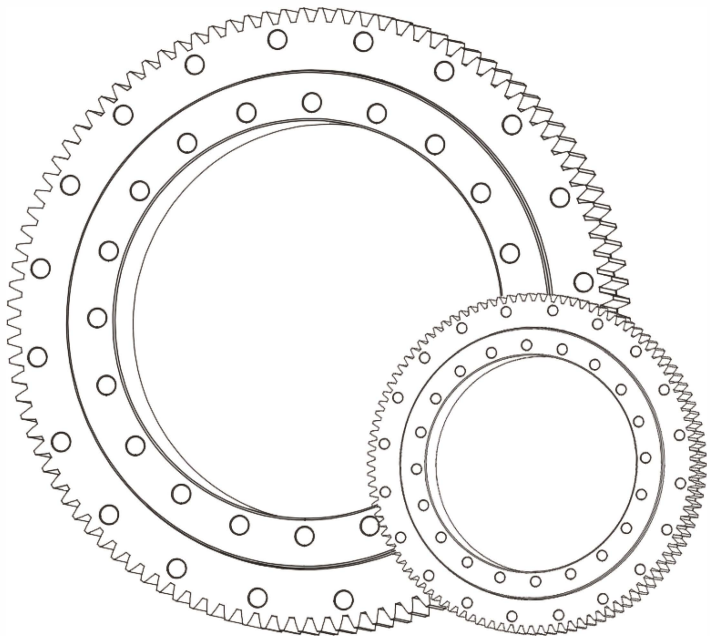
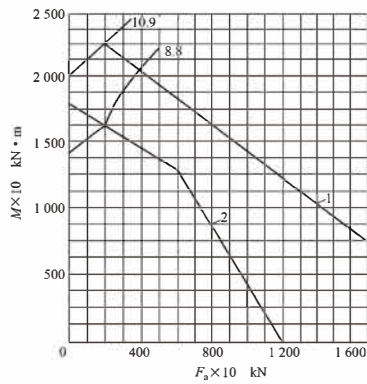
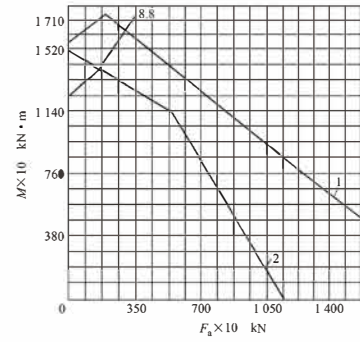
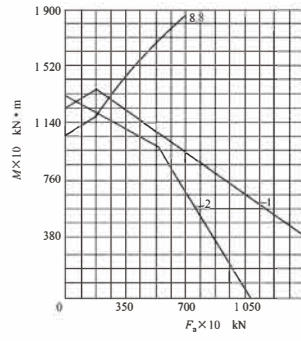
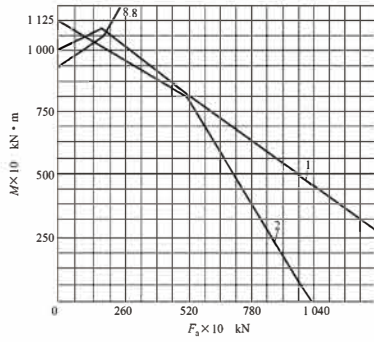

11 系列

单排交叉滚柱式回转支承 (11 系列)

Single row cross roller slewing bearing (11 series)

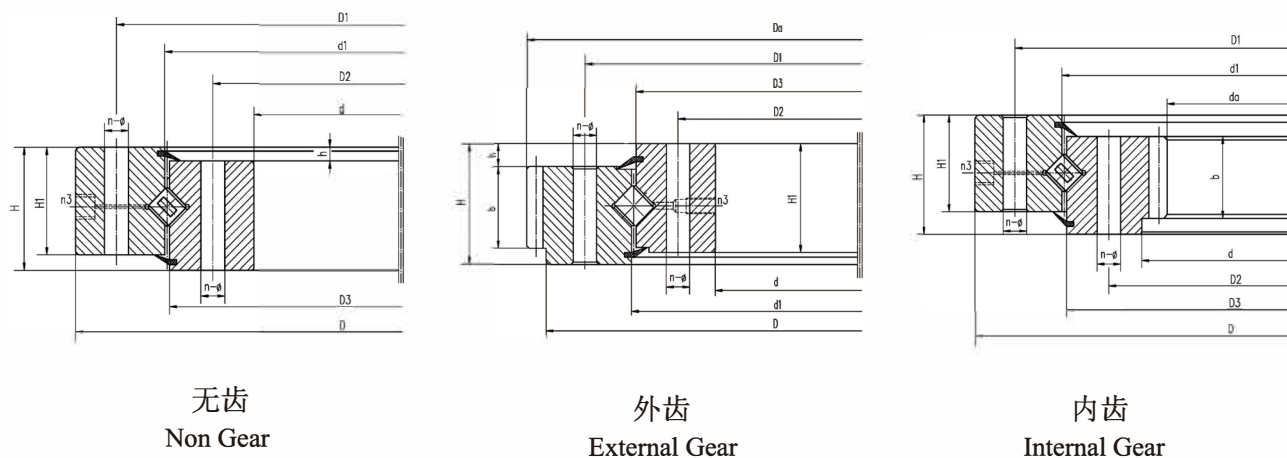

结构特点、性能、适用范围

单排交叉滚柱式回转支承，由两个座圈组成，结构紧凑、重量轻、制造精度高，装配间隙小，对安装精度要求高，滚柱为1:1交叉排列，能同时承受轴向力，倾翻力矩和较大的径向力，被广泛地用于起重运输、工程机械和光电产品上。

Structural characteristics, performance and scope of application

The single row cross roller slewing bearing is composed of two seat rings. It has compact structure, light weight, high manufacturing accuracy, small assembly gap and high requirement for installation accuracy. Rollers are 1:1 cross-arranged. It can bear axial force, overturning moment and large radial force at the same time. It is widely used in lifting transportation, construction machinery and opto-electronic products.

轴承型号 Bearing type			外形尺寸 Boundary dimensions			安装孔尺寸 Mounting hole diameter				结构尺寸 Structure dimensions				齿轮参数 Gear parameters						质量 Mass kg		
无齿式 Non-gear type	外齿式 External gear type	内齿式 Internal gear type	D	d	H	D1	D2	n	φ	D3	d1	H1	h	n3	m	外齿式 Ext gear		内齿式 Int gear			b	x
			mm			mm			mm	mm			Da mm			Z	da mm	Z	mm			
110.25.500	111.25.500	113.25.500	602	398	75	566	434	20	18	498	502	65	10	4/M10X1	5	630	123	365	74	60	+0.5	80
	112.25.500	114.25.500													6	630	120	360	62	60	+0.5	80
110.25.560	111.25.560	113.25.560	662	458	75	626	494	20	18	558	562	65	10	4/M10X1	5	690	135	425	86	60	+0.5	90
	112.25.560	114.25.560													6	690	112	426	72	60	+0.5	90
110.25.630	111.25.630	113.25.630	732	528	75	696	564	24	18	628	632	65	10	4/M10X1	6	774	126	492	83	60	+0.5	100
	112.25.630	114.30.630													8	776	94	488	62	60	+0.5	100
110.25.710	111.25.710	113.25.710	812	608	75	776	644	24	18	708	712	65	10	4/M10X1	6	852	139	570	96	60	+0.5	110
	112.25.710	114.25.710													8	856	104	568	72	60	+0.5	110
110.28.800	111.28.800	113.28.800	922	678	82	878	722	30	22	798	802	72	10	6/M10X1	8	968	118	632	80	65	+0.5	170
	112.28.800	114.28.800													10	970	94	630	64	65	+0.5	170
110.28.900	111.28.900	113.28.900	1022	778	82	978	822	30	22	898	902	72	10	6/M10X1	8	1064	130	736	93	65	+0.5	190
	112.28.900	114.28.900													10	1070	104	730	74	65	+0.5	190
110.28.1000	111.28.1000	113.28.1000	1122	878	82	1078	922	36	22	998	1002	72	10	6/M10X1	10	1190	116	820	83	65	+0.5	210
	112.28.1000	114.28.1000													12	1188	96	816	69	65	+0.5	210
110.28.1120	111.28.1120	113.28.1120	1242	998	82	1198	1042	36	22	1118	1122	72	10	6/M10X1	10	1300	127	940	95	65	+0.5	230
	112.28.1120	114.28.1120													12	1308	106	936	79	65	+0.5	230
110.32.1250	111.32.1250	113.32.1250	1390	1110	91	1337	1163	40	26	1248	1252	81	10	6/M10X1	12	1452	118	1044	88	75	+0.5	350
	112.32.1250	114.32.1250													14	1456	101	1036	75	75	+0.5	350
110.32.1400	111.32.1400	113.32.1400	1540	1260	91	1487	1313	40	26	1398	1402	81	10	6/M10X1	12	1608	131	1188	100	75	+0.5	400
	112.32.1400	114.32.1400													14	1610	112	1190	86	75	+0.5	400
110.32.1600	111.32.1600	113.32.1600	1740	1460	91	1687	1513	45	26	1598	1602	81	10	8/M10X1	14	1820	127	1386	100	75	+0.5	440
	112.32.1600	114.32.1600													16	1824	111	1376	87	75	+0.5	440
110.32.1800	111.32.1800	113.32.1800	1940	1660	91	1887	1713	45	33	1798	1802	81	10	8/M10X1	14	2016	141	1568	113	75	+0.5	500
	112.32.1800	114.32.1800													16	2016	123	1568	99	75	+0.5	500
110.40.2000	111.40.2000	113.40.2000	2178	1825	112	2110	1891	48	33	1998	2002	100	12	8/M10X1	16	2272	139	1728	109	90	+0.5	900
	112.40.2000	114.40.2000													18	2268	123	1728	97	90	+0.5	900
110.40.2240	111.40.2240	113.40.2240	2418	2065	112	2350	2131	48	33	2237	2243	100	12	8/M10X1	16	2496	153	1984	125	90	+0.5	1000
	112.40.2240	114.40.2240													18	2502	136	1980	111	90	+0.5	1000
110.40.2500	111.40.2500	113.40.2500	2678	2325	112	2610	2391	56	33	2497	2503	100	12	8/M10X1	18	2772	151	2232	125	90	+0.5	1100
	112.40.2500	114.40.2500													20	2780	136	2220	112	90	+0.5	1100

轴承型号 Bearing type			外形尺寸 Boundary dimensions			安装孔尺寸 Mounting hole diameter				结构尺寸 Structure dimensions				齿轮参数 Gear parameters						质量 Mass kg		
无齿式 Non-gear type	外齿式 External gear type	内齿式 Internal gear type	D	d	H	D1	D2	n	φ	D3	d1	H1	h	n3	m	外齿式 Ext gear		内齿式 Int gear			b	x
			mm			mm			mm	mm			Da mm			Z	da mm	Z	mm			
110. 40. 2800	111. 40. 2800	113. 40. 2800	2978	2625	112	2910	2691	56	33	2797	2803	100	12	8/M10X1	18	3078	168	2520	141	90	+0.5	1250
	112. 40. 2800	114. 40. 2800														3080	151	2520	127	90	+0.5	
110. 50. 3150	111. 50. 3150	113. 50. 3150	3376	2922	134	3286	3014	56	45	3147	3153	122	12	8/M10X1	20	3480	171	2820	142	110	+0.5	2150
	112. 50. 3150	114. 50. 3150														3476	155	2816	129	110	+0.5	
110. 50. 3550	111. 50. 3550	113. 50. 3550	3776	3322	134	3686	3414	56	45	3547	3553	122	12	8/M10X1	20	3880	191	3220	162	110	+0.5	2470
	112. 50. 3550	114. 50. 3550														3894	174	3212	147	110	+0.5	
110. 50. 4000	111. 50. 4000	113. 50. 4000	4226	3772	134	4136	3864	60	45	3997	4003	122	12	10/M10X1	22	4334	194	3652	167	110	+0.5	2800
	112. 50. 4000	114. 50. 4000														4350	171	3650	147	110	+0.5	
110. 50. 4500	111. 50. 4500	113. 50. 4500	4726	4272	134	4636	4364	60	45	4497	4503	122	12	10/M10X1	22	4940	217	4158	190	110	+0.5	3100
	112. 50. 4500	114. 50. 4500														4850	191	4150	167	110	+0.5	

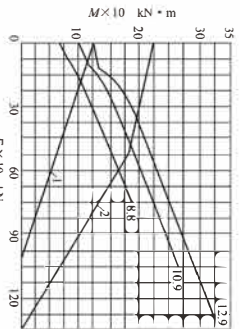

11*. 25. 500

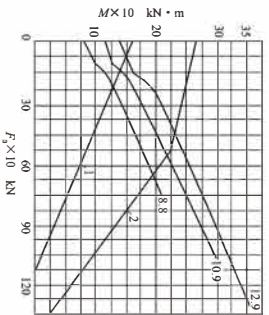

11*. 25. 560

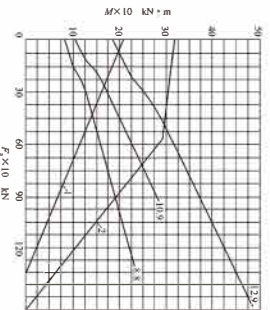

11*. 25. 630

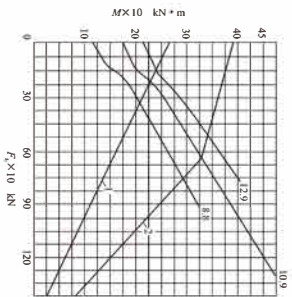

11*. 25. 710

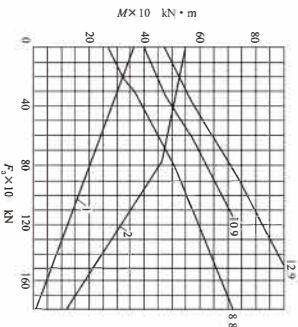

11*. 28. 800

11 系列负载曲线图 Series 11 Load Chart

恒久专注 冠军品质

11 系列负载曲线图

Series 11 Load Chart

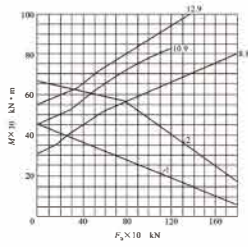

11* 28. 900

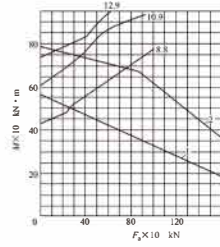

11* 28. 1000

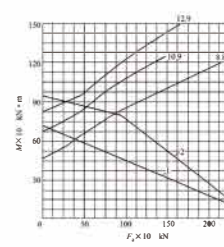

11* 28. 1120

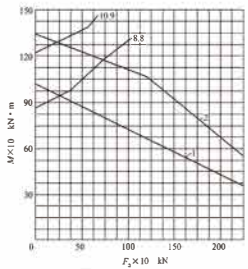

11* 32. 1250

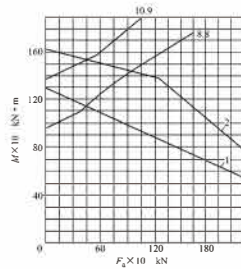

11* 32. 1400

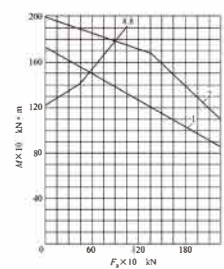

11* 32. 1600

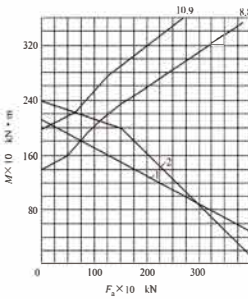

11* 32. 1800

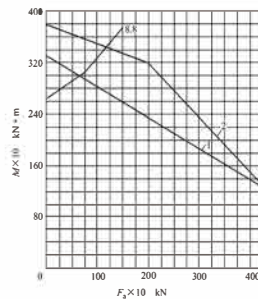

11* 40. 2000

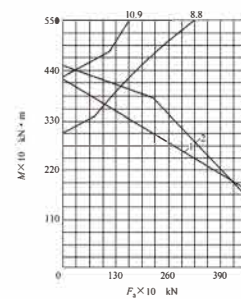

11* 40. 2240

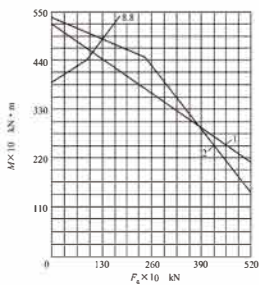

11* 40. 2500

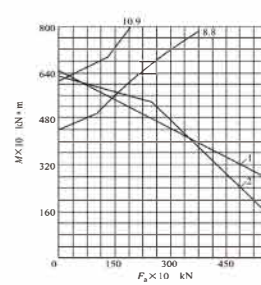

11* 40. 2800

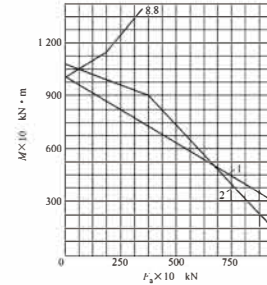

11* 50. 3150

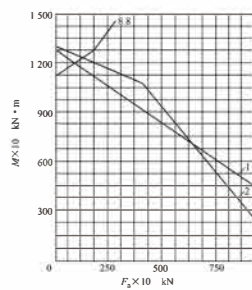

11* 50. 3550

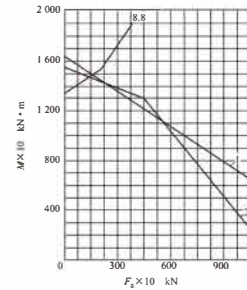

11* 50. 4000

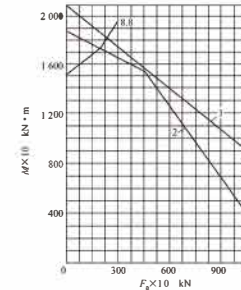

11* 50. 4500

02 系列

双排球式回转支承 (02 系列)

Double row ball slewing bearing (02 series)

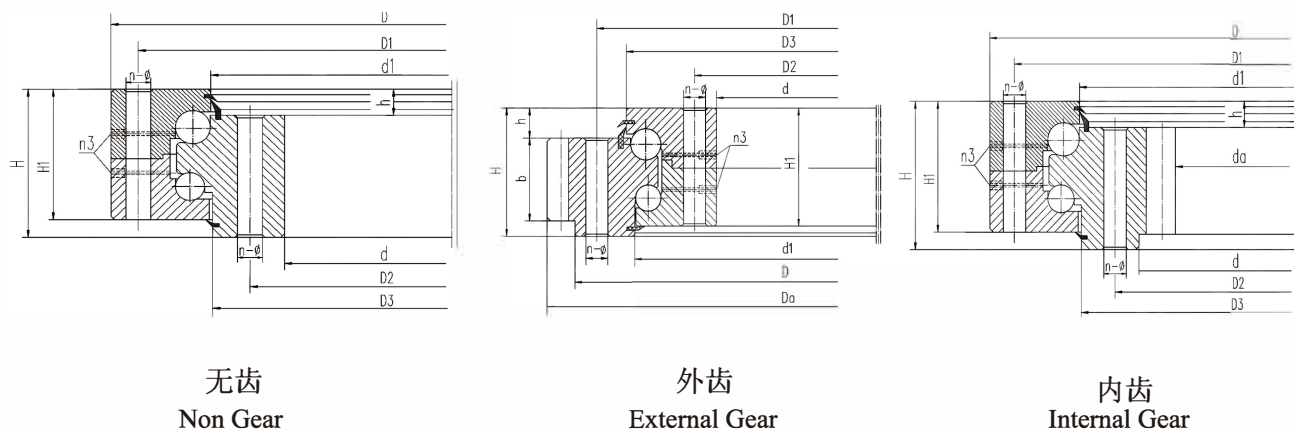

无齿
Non Gear

外齿
External Gear

内齿
Internal Gear

结构特点、性能、适用范围

双排球式回转支承具有三个座圈、钢球和隔离块，可直接排入上下滚道，根据受力状况，安排了上下两排直径不同的钢球。这种开式装配非常方便，上下圆弧滚道的承载角都为 75° ，能承受很大的轴向力和倾翻力矩。当径向力大于0.1倍的轴向力时，滚道须特殊设计。双排球式回转支承的轴向、径向尺寸都比较大，结构紧固。特别适用于要求中等以上直径的塔式起重机，汽车起重机等装卸机械上。

Structural characteristics, performance and scope of application

The double row ball slewing bearing has three seat rings. The steel balls and isolators can be directly arranged into the upper and lower raceways. According to the stress conditions, the upper and lower rows of steel balls with different diameters are arranged. This kind of open assembly is very convenient. The bearing angle of the upper and lower arc raceway is 75° . It can bear a great deal of axial force and overturning moment. When the radial force is greater than 0.1 times the axial force, the raceway must be specially designed. The axial and radial dimensions of the double row ball slewing bearing are relatively large and the structure is fastened. It is especially suitable for handling tower cranes, truck cranes and other loading machines that require medium or above diameters.

轴承型号 Bearing type			外形尺寸 Boundary dimensions			安装孔尺寸 Mounting hole diameter			结构尺寸 Structure dimensions					齿轮参数 Gear parameters				质量 Mass kg				
无齿式 Non-gear type	外齿式 External gear type	内齿式 Internal gear type	D	d	H	D1	D2	n	φ	D3	d1	H1	h	n3	m	外齿式 Ext gear		内齿式 Int gear		b	x	
																Da mm	Z	da mm	Z			
020.25.500	021.25.500	023.25.500	616	384	106	580	420	20	18	523	517	96	26	4/M10X1	5	645	126	355	72	60	+0.5	100
	022.25.500	024.25.500				(477)	(483)			(477)												
020.25.560	021.25.560	023.25.560	676	444	106	640	480	20	18	583	577	96	26	4/M10X1	5	705	138	415	84	60	+0.5	115
	022.25.560	024.25.560				(537)	(543)			(537)												
020.25.630	021.25.630	023.25.630	746	514	106	710	550	24	18	653	647	96	26	4/M10X1	6	792	129	480	81	60	+0.5	130
	022.25.630	024.25.630				(607)	(613)			(607)												
020.25.710	021.25.710	023.25.710	826	594	106	790	630	24	18	733	727	96	26	4/M10X1	6	864	141	558	94	60	+0.5	140
	022.25.710	024.25.710				(687)	(693)			(687)												
020.30.800	021.30.800	023.30.800	942	658	124	898	702	30	22	828	822	114	29	6/M10X1	8	984	120	616	78	80	+0.5	200
	022.30.800	024.30.800				(771)	(778)			(771)												
020.30.900	021.30.900	023.30.900	1042	758	124	998	802	30	22	928	922	114	29	6/M10X1	8	1088	133	712	90	80	+0.5	250
	022.30.900	024.30.900				(871)	(878)			(871)												
020.30.1000	021.30.1000	023.30.1000	1142	858	124	1098	902	36	22	1028	1022	114	29	6/M10X1	10	1200	117	810	82	80	+0.5	300
	022.30.1000	024.30.1000				(971)	(978)			(971)												
020.30.1120	021.30.1120	023.30.1120	1262	978	124	1218	1022	36	22	1148	1142	114	29	6/M10X1	10	1320	129	920	93	80	+0.5	340
	022.30.1120	024.30.1120				(1091)	(1098)			(1091)												
020.40.1250	021.40.1250	023.40.1250	1426	1074	160	1374	1126	40	26	1286	1282	150	39	6/M10X1	12	1500	122	1008	85	90	+0.5	580
	022.40.1250	024.40.1250				(1218)	(1218)			(1218)												
020.40.1400	021.40.1400	023.40.1400	1576	1224	160	1524	1272	40	26	1436	1432	150	39	6/M10X1	12	1644	134	1152	97	90	+0.5	650
	022.40.1400	024.40.1400				(1364)	(1368)			(1364)												
020.40.1600	021.40.1600	023.40.1600	1776	1424	160	1724	1476	45	26	1636	1632	150	39	8/M10X1	14	1848	129	1344	97	90	+0.5	750
	022.40.1600	024.40.1600				(1564)	(1568)			(1564)												
020.40.1800	021.40.1800	023.40.1800	1976	1624	160	1924	1676	45	26	1836	1832	150	39	8/M10X1	14	2058	144	1540	111	90	+0.5	820
	022.40.1800	024.40.1800				(1764)	(1768)			(1764)												
020.50.2000	021.50.2000	023.50.2000	2215	1785	190	2149	1851	48	33	2038	2032	178	47	8/M10X1	16	2304	141	1696	107	120	+0.5	1150
	022.50.2000	024.50.2000				(1962)	(1968)			(1962)												
020.50.2240	021.50.2240	023.50.2240	2455	2025	190	2389	2091	48	33	2278	2272	178	47	8/M10X1	16	2544	156	1936	122	120	+0.5	1500
	022.50.2240	024.50.2240				(2202)	(2208)			(2202)												

02系列负载曲线图
Series 02 Load Chart

轴承型号 Bearing type			外形尺寸 Boundary dimensions			安装孔尺寸 Mounting hole diameter				结构尺寸 Structure dimensions				齿轮参数 Gear parameters						质量 Mass kg		
无齿式 Non-gear type	外齿式 External gear type	内齿式 Internal gear type	D	d	H	D1	D2	φ	D3	d1	H1	h	n3	m	外齿式 Ext gear		内齿式 Int gear		b		x	
			mm			mm			n	mm					Da mm	Z	da mm	Z				mm
020. 50. 2500	021. 50. 2500	023. 50. 2500	2715	2285	190	2649	2351	56	33	2538	2532	178	47	8/M10X1	18	2804	153	2196	123	120	+0.5	1700
	022. 50. 2500	024. 50. 2500								(2468)	(2462)				20	2820	138	2180	110	120	+0.5	1700
020. 50. 2800	021. 50. 2800	023. 50. 2800	3015	2585	190	2949	2651	56	33	2838	2832	178	47	8/M10X1	18	3114	170	2484	139	120	+0.5	1900
	022. 50. 2800	024. 50. 2800								(2768)	(2762)				20	3120	153	2480	125	120	+0.5	1900
020. 60. 3150	021. 60. 3150	023. 60. 3150	3428	2872	226	3338	2962	56	45	3198	3192	214	56	8/M10X1	20	3540	174	2760	139	150	+0.5	3300
	022. 60. 3150	024. 60. 3150								(3108)	(3102)				22	3542	158	2750	126	150	+0.5	3300
020. 60. 3550	021. 60. 3550	023. 60. 3550	3828	3272	226	3738	3362	56	45	3598	3592	214	56	8/M10X1	20	3940	194	3160	159	150	+0.5	3700
	022. 60. 3550	024. 60. 3550								(3508)	(3502)				22	3938	176	3168	145	150	+0.5	3700
020. 60. 4000	021. 60. 4000	023. 60. 4000	4278	3722	226	4188	3812	60	45	4048	4042	214	56	10/M10X1	22	4400	197	3608	165	150	+0.5	4200
	022. 60. 4000	024. 60. 4000								(3958)	(3952)				25	4400	173	3600	145	150	+0.5	4200
020. 60. 4500	021. 60. 4500	023. 60. 4500	4778	4222	226	4688	4312	60	45	4548	4542	214	56	10/M10X1	22	4884	219	4114	188	150	+0.5	4700
	022. 60. 4500	024. 60. 4500								(4458)	(4452)				25	4900	193	4100	165	150	+0.5	4700

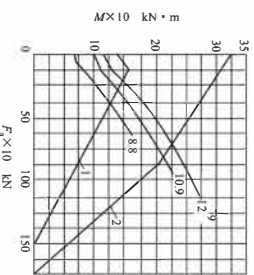

02*. 25. 500

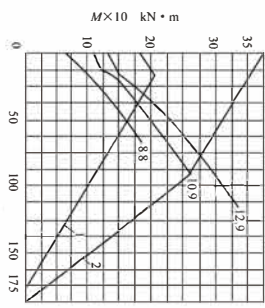

02*. 25. 560

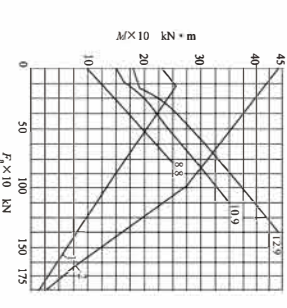

02*. 25. 630

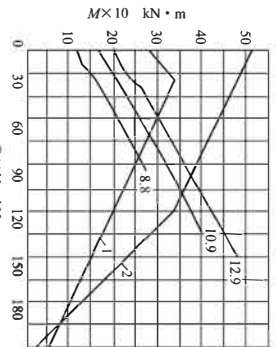

02*. 25. 710

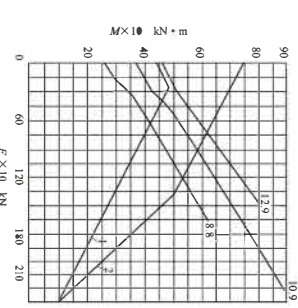

02*. 30. 800

02 系列负载曲线图 Series 02 Load Chart

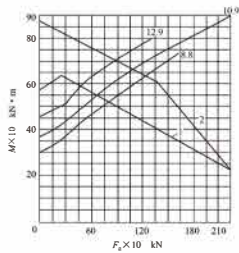

02* 30.900

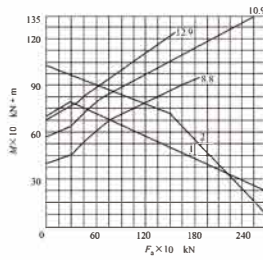

02* 30.1000

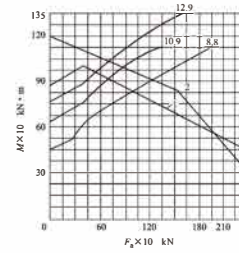

02* 30.1120

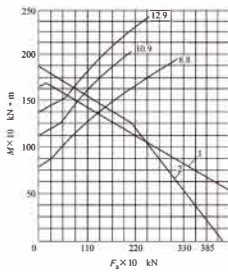

02* 40.1250

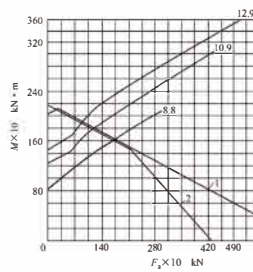

02* 40.1400

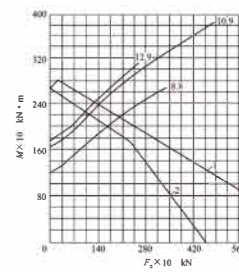

02* 40.1600

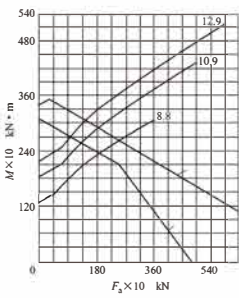

02* 40.1800

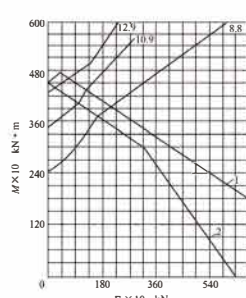

02* 50.2000

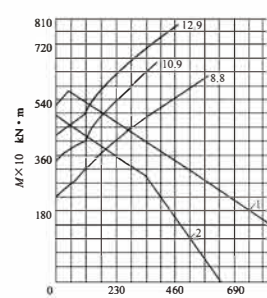

02* 50.2240

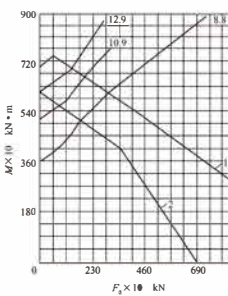

02* 50.2500

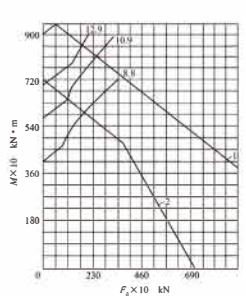

02* 50.2800

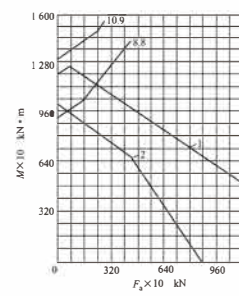

02* 60.3150

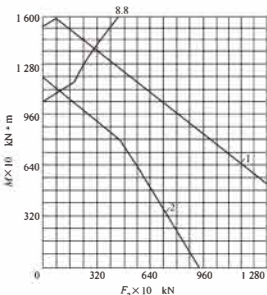

02* 60.3550

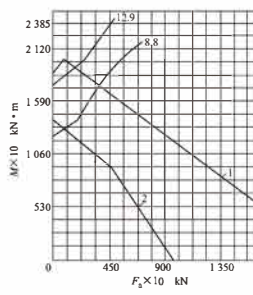

02* 60.4000

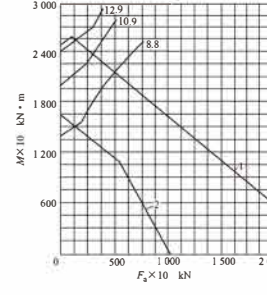

02* 60.4500

13 系列

三排滚柱式回转支承 (13 系列)

Three row roller slewing bearing (13 series)

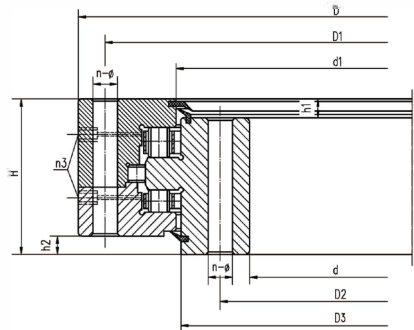

无齿
Non Gear

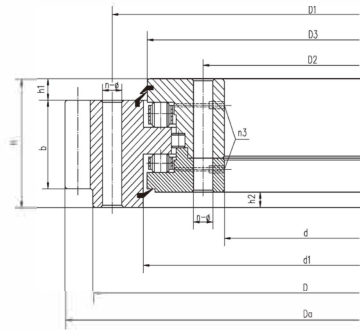

外齿
External Gear

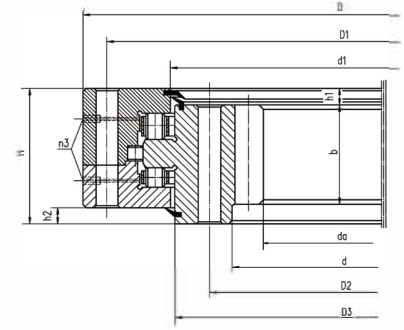

内齿
Internal Gear

结构特点、性能、适用范围

三排滚柱式回转支承有三个座圈，上下及径向滚道各自分开，使得每一排滚柱的负载都能确切地加以确定。能够同时承受各种载荷，是四种结构产品中承载能力最大的一种，轴、径向尺寸都较大，结构牢固，特别适用于要求较大直径的重型机械，如斗轮堆取料机、轮式起重机、船用起重机、港口起重机、钢包回转台及大吨位汽车起重机等机械上。

Structural characteristics, performance and scope of application

Three row roller slewing bearing have three seat rings, the upper and lower raceways and the radial raceways are separated, so that the load of each row of roller can be determined accurately. Being able to bear all kinds of loads at the same time, it is the largest one of the four structural products with large axial and radial dimensions and firm structure. It is especially suitable for heavy machinery requiring larger diameter, such as bucket wheel stacker and reclaimer, wheel crane, marine crane, port crane, ladle turret, large tonnage truck crane and so on.

轴承型号 Bearing type			外形尺寸 Boundary dimensions			安装孔尺寸 Mounting hole diameter				结构尺寸 Structure dimensions					齿轮参数 Gear parameters						质量 Mass kg	
无齿式 Non-gear type	外齿式 External gear type	内齿式 Internal gear type	D	d	H	D1	D2	n	φ	D3	d1	H1	h	n3	m	外齿式 Ext gear		内齿式 Int gear		b		x
			mm			mm			mm	mm						Da mm	Z	da mm	Z			
130.25.500	131.25.500	133.25.500	634	366	148	598	402	24	18	537	526	32	10	2X4/M10X1	5	665	130	335	68	80	+0.5	224
	132.25.500	134.25.500								474	463	32	10	2X4/M10X1	6	666	108	336	57	80	+0.5	224
130.25.560	131.25.560	133.25.560	694	426	148	658	462	24	18	597	586	32	10	2X4/M10X1	5	725	142	395	80	80	+0.5	240
	132.25.560	134.25.560								534	523	32	10	2X4/M10X1	6	726	118	396	67	80	+0.5	240
130.25.630	131.25.630	133.25.630	764	496	148	728	532	28	18	667	656	32	10	2X4/M10X1	6	810	132	456	77	80	+0.5	270
	132.25.630	134.25.630								(604)	593	32	10	2X4/M10X1	8	808	98	456	58	80	+0.5	270
130.25.710	131.25.710	133.25.710	844	576	148	808	612	28	18	747	736	32	10	2X4/M10X1	6	888	145	534	90	80	+0.5	300
	132.25.710	134.25.710								(684)	673	32	10	2X4/M10X1	8	888	108	536	68	80	+0.5	300
130.32.800	131.32.800	133.32.800	964	636	182	920	680	36	22	841	830	32	10	2X4/M10X1	8	1008	123	592	75	120	+0.5	500
	132.32.800	134.32.800								(770)	759	40	10	2X4/M10X1	10	1010	98	590	60	120	+0.5	500
130.32.900	131.32.900	133.32.900	1064	736	182	1020	780	36	22	941	930	40	10	2X4/M10X1	8	1104	135	688	87	120	+0.5	600
	132.32.900	134.32.900								(870)	(859)	40	10	2X5/M10X1	10	1110	108	690	70	120	+0.5	600
130.32.1000	131.32.1000	133.32.1000	1164	836	182	1120	880	40	22	1041	1030	40	10	2X5/M10X1	10	1220	119	780	79	120	+0.5	680
	132.32.1000	134.32.1000								(970)	(959)	40	10	2X5/M10X1	12	1224	99	780	66	120	+0.5	680
130.32.1120	131.32.1120	133.32.1120	1284	956	182	1240	1000	40	22	1161	1150	40	10	2X5/M10X1	10	1340	131	900	91	120	+0.5	820
	132.32.1120	134.32.1120								(1090)	1079	40	10	2X5/M10X1	12	1344	109	900	76	120	+0.5	820
130.40.1250	131.40.1250	133.40.1250	1445	1055	220	1393	1107	45	26	1300	1290	50	10	2X5/M10X1	12	1512	123	984	83	150	+0.5	1200
	132.40.1250	134.40.1250								(1210)	1200	50	10	2X5/M10X1	14	1512	105	980	71	150	+0.5	1200
130.40.1400	131.40.1400	133.40.1400	1595	1205	220	1543	1257	45	26	1450	1440	50	10	2X5/M10X1	12	1668	136	1140	96	150	+0.5	1300
	132.40.1400	134.40.1400								(1360)	1350	50	10	2X5/M10X1	14	1666	116	1134	80	150	+0.5	1300
130.40.1600	131.40.1600	133.40.1600	1795	1405	220	1743	1457	48	26	1650	1640	50	10	2X5/M10X1	14	1876	131	1330	96	150	+0.5	1520
	132.40.1600	134.40.1600								(1560)	1550	50	10	2X5/M10X1	16	1872	114	1328	84	150	+0.5	1520
130.40.1800	131.40.1800	133.40.1800	1995	1605	220	1943	1657	48	26	1850	1840	50	10	2X5/M10X1	14	2072	145	1526	110	150	+0.5	1750
	132.40.1800	134.40.1800								1760	1750	50	10	2X5/M10X1	16	2080	127	1520	96	150	+0.5	1750
130.45.2000	131.45.2000	133.45.2000	2221	1779	231	2155	1845	60	33	2055	2033	54	12	2X6/M10X1	16	2304	141	1696	107	160	+0.5	2400
	132.45.2000	134.45.2000								(1967)	1945	54	12	2X6/M10X1	18	2304	125	1692	95	160	+0.5	2400
130.45.2240	131.45.2240	133.45.2240	2461	2019	231	2395	2085	60	33	2295	2273	54	12	2X6/M10X1	16	2560	157	1920	121	160	+0.5	2700
	132.45.2240	134.25.2240								2207	2185	54	12	2X6/M10X1	18	2556	139	1926	108	160	+0.5	2700

轴承型号 Bearing type			外形尺寸 Boundary dimensions			安装孔尺寸 Mounting hole diameter				结构尺寸 Structure dimensions					齿轮参数 Gear parameters						质量 Mass kg	
无齿式 Non-gear type	外齿式 External gear type	内齿式 Internal gear type	D	d	H	D1	D2	n	φ	D3	d1	H1	h	n3	m	外齿式 Ext gear		内齿式 Int gear		b		x
			mm			mm			mm	mm			Da mm			Z	da mm	Z	mm			
130.45.2500	131.45.2500	133.45.2500	2721	2279	231	2655	2345	72	33	2555	2533	54	12	2X8/M10X1	18	2826	154	2178	122	160	+0.5	3000
	132.45.2500	134.45.2500								2467	2445	54	12	2X8/M10X1	20	2820	138	2180	110	160	+0.5	3000
130.45.2800	131.45.2800	133.45.2800	3021	2579	231	2955	2645	72	33	2855	2833	54	12	2X8/M10X1	18	3114	170	2484	139	160	+0.5	3400
	132.45.2800	134.45.2800								2767	2745	54	12	2X8/M10X1	20	3120	153	2480	125	160	+0.5	3400
130.50.3150	131.50.3150	133.50.3150	3432	2868	270	3342	2958	72	45	3213	3196	65	12	2X8/M10X1	20	3540	174	2760	139	180	+0.5	5000
	132.50.3150	134.50.3150								3104	3087	65	12	2X8/M10X1	22	3542	158	2750	126	180	+0.5	5000
130.50.3550	131.50.3550	133.50.3550	3832	3268	270	3742	3358	72	45	3613	3596	65	12	2X8/M10X1	20	3940	194	3160	159	180	+0.5	5600
	132.50.3550	134.50.3550								3504	3487	65	12	2X8/M10X1	22	3938	176	3146	144	180	+0.5	5600
130.50.4000	131.50.4000	133.50.4000	4282	3718	270	4192	3808	80	45	4063	4046	65	12	2X8/M10X1	22	4400	197	3608	165	180	+0.5	6400
	132.50.4000	134.50.4000								3954	3937	65	12	2X8/M10X1	25	4400	173	3600	145	180	+0.5	6400
130.50.4500	131.50.4500	133.50.4500	4782	4218	270	4692	4308	80	45	4563	4546	65	12	2X8/M10X1	22	4906	220	4114	188	185	+0.5	6942
	132.50.4500	134.50.4500								4454	4437	65	12	2X8/M10X1	25	4900	193	4100	165	185	+0.5	6942

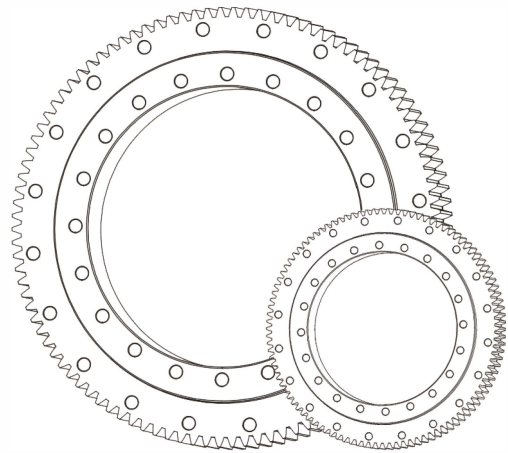

13 系列负载曲线图

Series 13 Load Chart

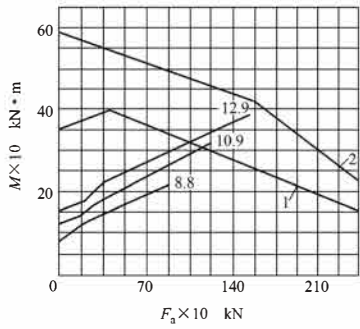

13*. 25. 500

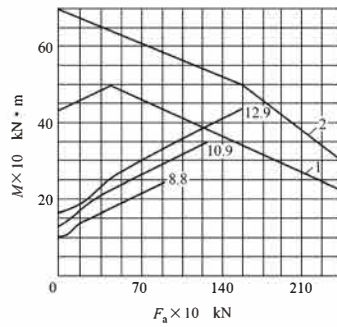

13*. 25. 560

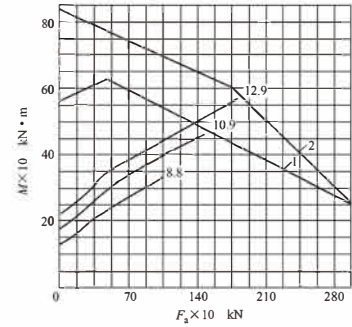

13*. 25. 630

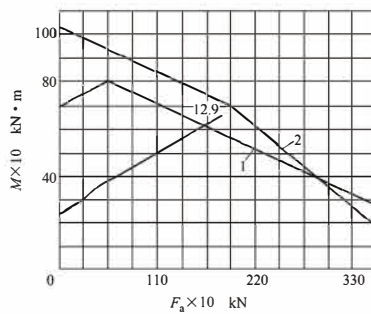

13*. 25. 710

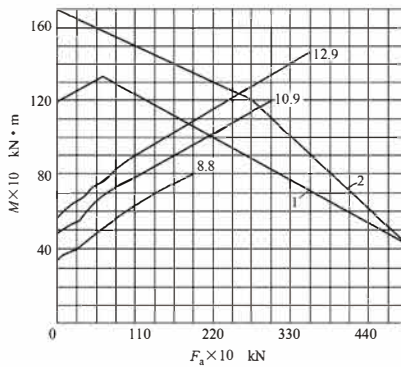

13*. 32. 800

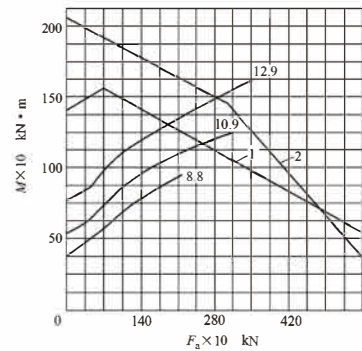

13*. 32. 900

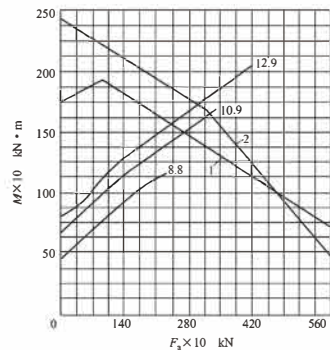

13*. 32. 1000

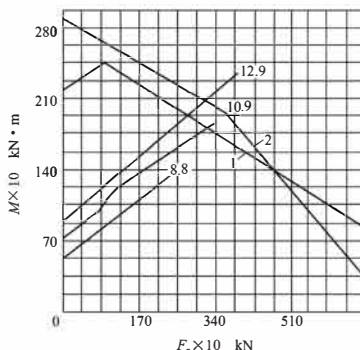

13*. 32. 1120

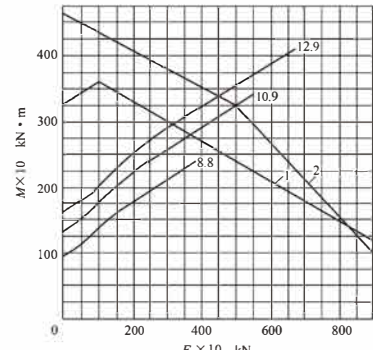

13*. 40. 1250

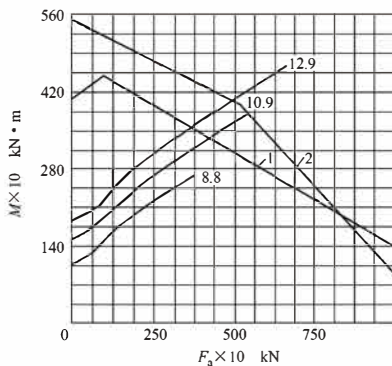

13*. 40. 1400

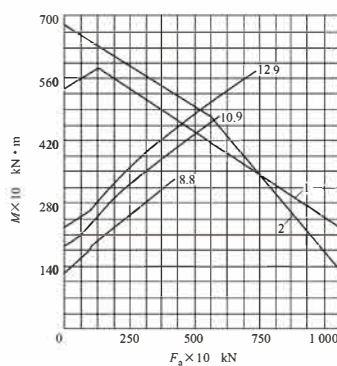

13*. 40. 1600

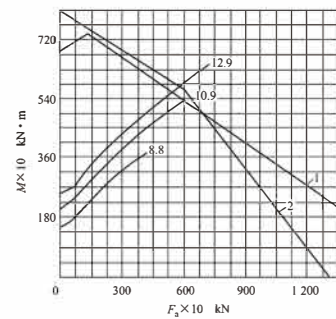

13*. 40. 1800

13 系列负载曲线图

Series 13 Load Chart

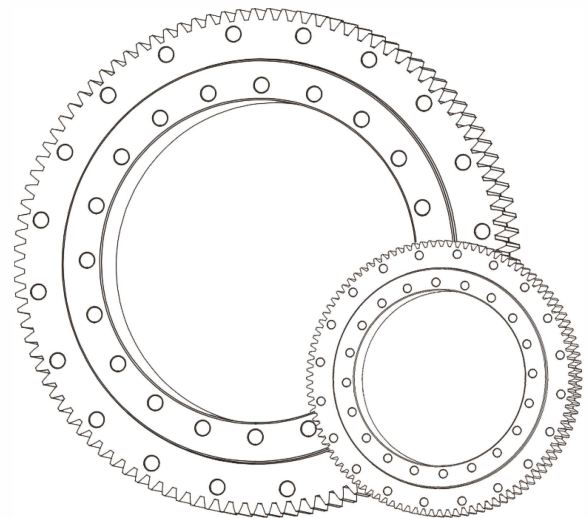
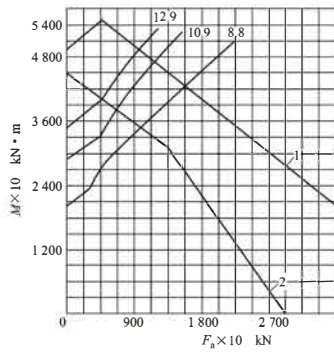
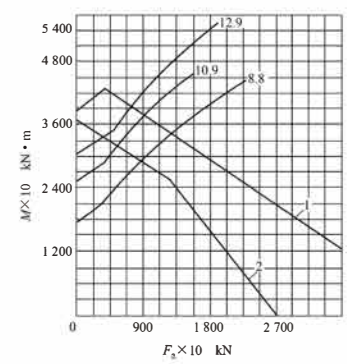
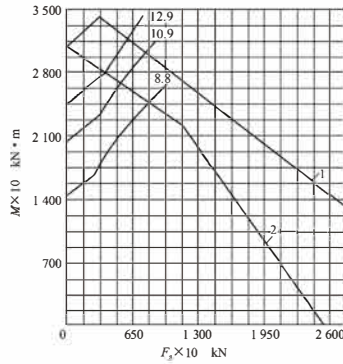
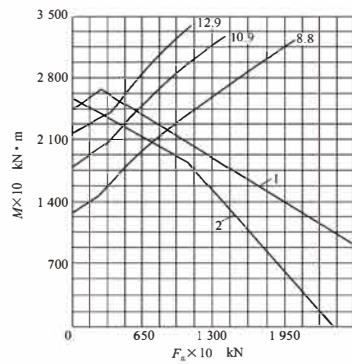
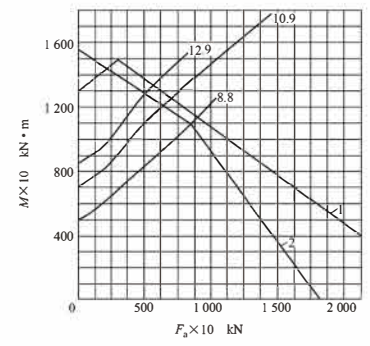
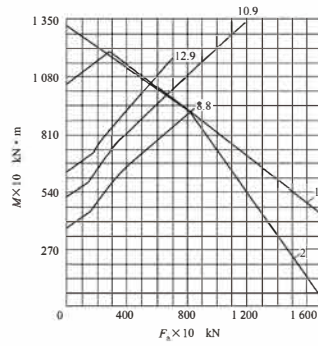
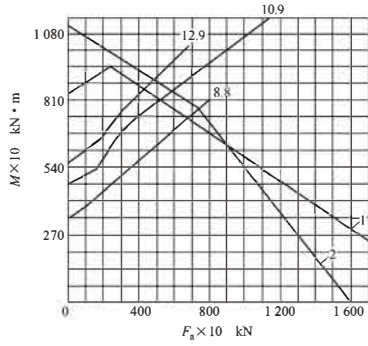

回转支承类型和系列二 Types and series two of slewing bearings

回转支承编号方法:

The standard slewing bearing numbering method:

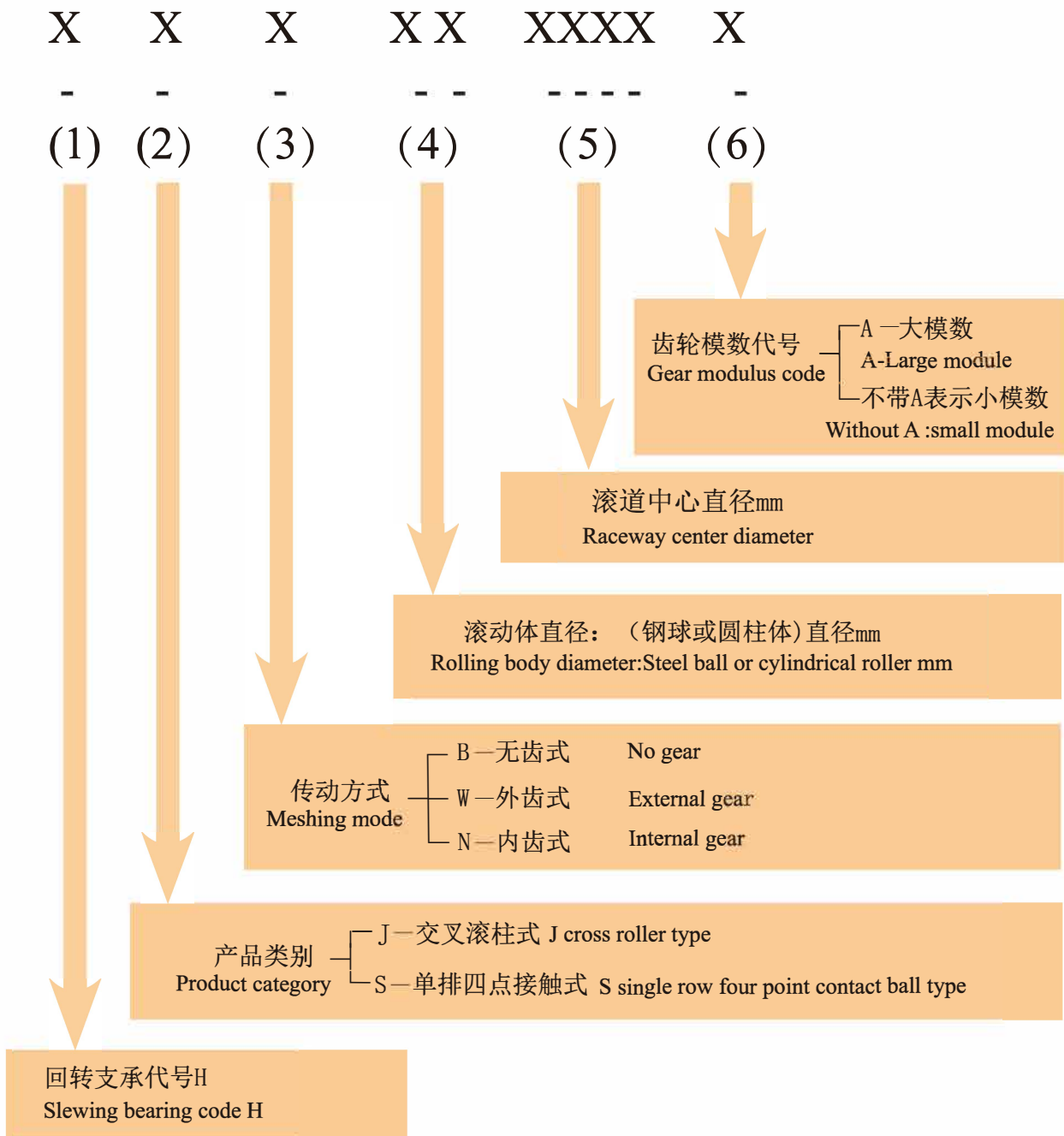

HJ 系列

单排交叉滚柱式回转支承 (HJ 系列)

Single row cross roller slewing bearing(HJ series)

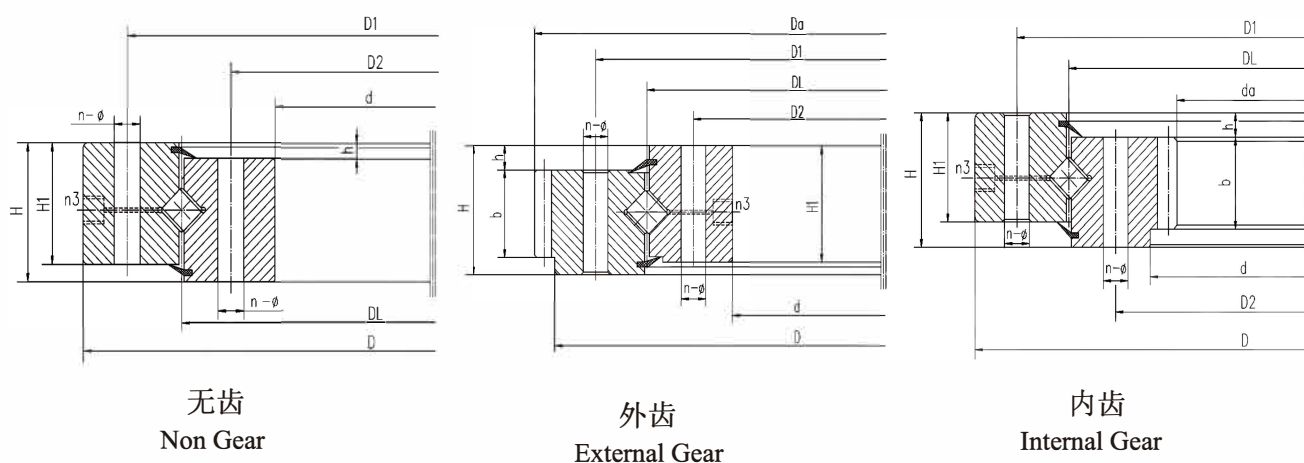

结构特点、性能、适用范围

单排交叉滚柱式回转支承，由两个座圈组成，结构紧凑、重量轻、制造精度高，装配间隙小，对安装精度要求高，滚柱为 1:1 交叉排列，能同时承受轴向力，倾翻力矩和较大的径向力，被广泛地用于起重运输、工程机械和光电产品上。

Structural characteristics, performance and scope of application

The single row crossed roller slewing bearing is composed of two seat rings, which design in compact structure and light weight, the clearance is small when assembly, so need high installation precision. The rollers are 1:1 cross arranged, it can bear the axial force, tilting moment and relatively large radial force. It is widely used for hoisting, transportation, construction machinery, and the opto-electronic products.

轴承型号 Bearing type			外形尺寸 Boundary dimensions			安装孔尺寸 Mounting hole diameter			结构尺寸 Structure dimensions					齿轮参数 Gear parameters						质量 Mass kg		
无齿式 Non-gear type	外齿式 External gear type	内齿式 Internal gear type	D	d	H	D1	D2	n	ϕ	DL	H1	h	n3	b	m	外齿式 Ext gear		内齿式 Int gear				
			mm			mm			mm	mm				mm		χ	$D_{a_{mm}}$	Z	χ		$d_{a_{mm}}$	Z
HJB. 20. 625	HJW. 20. 625	HJN. 20. 625	725	525	80	685	565	18	18	625	68	12	3	60	5	+1.25	751.9	146	+0.35	498.8	101	100
	HJW. 20. 625A	HJN. 20. 625A													6	+1.00	755.5	122	+0.35	496.7	84	
HJB. 20. 720	HJW. 20. 720	HJN. 20. 720	820	620	80	780	660	18	18	720	68	12	3	60	6	+1.25	860.3	139	+0.35	586.6	99	120
	HJW. 20. 720A	HJN. 20. 720A													8	+0.85	861.1	104	+0.35	582.3	74	
HJB. 30. 820	HJW. 30. 820	HJN. 30. 820	940	705	95	893	749	24	20	820	83	12	4	70	6	+1.25	980.4	159	+0.35	664.5	112	210
	HJW. 30. 820A	HJN. 30. 820A													10	+0.85	986.2	95	+0.35	658	67	
HJB. 30. 880	HJW. 30. 880	HJN. 30. 880	1000	760	95	956	800	24	20	880	83	12	4	70	8	+1.0	1047.5	127	+0.35	718.2	91	230
	HJW. 30. 880A	HJN. 30. 880A													10	+0.85	1046.3	101	+0.35	707.9	72	
HJB. 30. 1020	HJW. 30. 1020	HJN. 30. 1020	1170	875	95	1120	930	24	22	1020	80	15	4	70	8	+1.25	1219.3	148	+0.35	830.1	105	300
	HJW. 30. 1020A	HJN. 30. 1020A													10	+1.00	1219.2	118	+0.35	827.8	84	
HJB. 36. 1220	HJW. 36. 1220	HJN. 36. 1220	1365	1075	120	1310	1130	36	24	1220	105	15	6	90	10	+1.25	1424.9	138	+0.35	1027.8	104	450
	HJW. 36. 1220A	HJN. 36. 1220A													12	+0.85	1435.9	116	+0.35	1017.3	86	
HJB. 36. 1250	HJW. 36. 1250	HJN. 36. 1250	1400	1090	120	1350	1150	36	26	1250	105	15	6	90	10	+0.35	1443	143	+0.35	1037	105	520
	HJW. 36. 1250A	HJN. 36. 1250A													12	+0.85	1449.6	117	+0.35	1028.8	87	
HJB. 36. 1435	HJW. 36. 1435	HJN. 36. 1435	1595	1278	120	1535	1335	36	26	1435	105	15	6	90	12	+1.0	1655.5	134	+0.35	1221.1	103	610
	HJW. 36. 1435A	HJN. 36. 1435A													14	+0.85	1661.2	115	+0.35	1214.8	88	
HJB. 45. 1540	HJW. 45. 1540	HJN. 45. 1540	1720	1360	140	1660	1420	42	26	1540	122	18	6	110	12	+1.4	1780.8	144	+0.35	1293.1	109	732
	HJW. 45. 1540A	HJN. 45. 1540A													14	+1.0	1791.1	124	+0.35	1284.8	93	
HJB. 45. 1700	HJW. 45. 1700	HJN. 45. 1700	1875	1525	140	1815	1585	42	29	1700	122	18	6	110	14	+1.0	1945.4	135	+0.35	1452.7	105	844
	HJW. 45. 1700A	HJN. 45. 1700A													16	+1.0	1950.8	118	+0.35	1452.3	92	
HJB. 45. 1880	HJW. 45. 1880	HJN. 45. 1880	2100	1665	160	2030	1740	48	32	1880	140	20	6	115	14	+1.25	2189.8	152	+0.35	1592.6	115	1400
	HJW. 45. 1880A	HJN. 45. 1880A													18	+1.0	2194.6	118	+0.35	1579.9	89	
HJB. 45. 2115	HJW. 45. 2115	HJN. 45. 2115	2325	1900	160	2245	1980	48	32	2115	140	20	6	115	16	+1.25	2406.5	146	+0.35	1804.1	114	1600
	HJW. 45. 2115A	HJN. 45. 2115A													20	+1.0	2418.4	117	+0.35	1795.4	91	
HJB. 45. 2370	HJW. 45. 2370	HJN. 45. 2370	2600	2146	180	2520	2220	48	32	2370	158	22	6	130	18	+1.25	2307.3	146	+0.35	2065.6	116	2100
	HJW. 45. 2370A	HJN. 45. 2370A													22	+1.0	2704.4	119	+0.35	2040.9	94	
HJB. 45. 2600	HJW. 45. 2600	HJN. 45. 2600	2835	2365	180	2750	2450	54	36	2600	158	22	6	130	18	+1.25	2941.7	159	+0.35	2263.5	127	2400
	HJW. 45. 2600A	HJN. 45. 2600A													22	+1.0	2946.9	130	+0.35	2260.8	104	
HJB. 50. 2820	HJW. 50. 2820	HJN. 50. 2820	3085	2555	200	3000	2640	54	36	2820	178	22	6	150	20	+1.25	3188.4	155	+0.35	2455	124	3400
	HJW. 50. 2820A	HJN. 50. 2820A													25	+1.0	3198.4	124	+0.35	2444.1	99	
HJB. 50. 3120	HJW. 50. 3120	HJN. 50. 3120	3400	2840	200	3310	2930	54	36	3120	178	22	6	150	22	+1.25	3507.2	155	+0.35	2722	125	4000
	HJW. 50. 3120A	HJN. 50. 3120A													25	+1.25	3509.6	136	+0.35	2719	110	
HJB. 50. 3580	HJW. 50. 3580	HJN. 50. 3580	3920	3240	240	3820	3340	60	40	3580	218	22	6	190	22	+1.25	4036.1	179	+0.35	3118.4	143	6700
	HJW. 50. 3580A	HJN. 50. 3580A													25	+1.25	4035.6	157	+0.35	3118.8	126	
HJB. 50. 4030	HJW. 50. 4030	HJN. 50. 4030	4370	3690	240	4270	3790	66	40	4030	218	22	6	190	22	+1.25	4520.6	201	+0.35	3558.3	163	7700
	HJW. 50. 4030A	HJN. 50. 4030A													28	+1.25	4522	157	+0.35	3549	128	
HJB. 50. 4540	HJW. 50. 4540	HJN. 50. 4540	4860	4210	240	4760	4310	72	40	4540	218	22	6	190	22	+1.25	4983	222	+0.35	4042.2	185	8760
	HJW. 50. 4540A	HJN. 50. 4540A													30	+1.25	4992.9	162	+0.35	4042.4	136	

HS 系列

单排四点接触球回转支承 (HS 系列)

Single row four point contact ball slewing bearing (HS series)

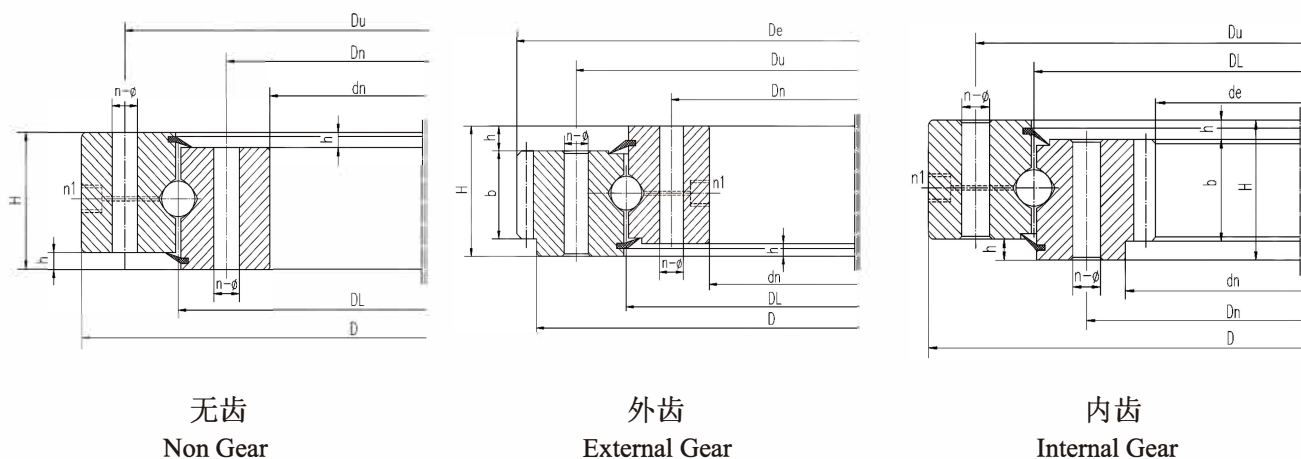

结构特点、性能、适用范围

单排四点接触球式回转支承由两个座圈组成，结构紧凑、重量轻、钢球与圆弧滚道四点接触，能同时承受轴向力、径向力和倾翻力矩。回转式输送机、焊接操作机、中小型起重机和挖掘机等工程机械均可选用。

Structural characteristics, performance and scope of application

The single-row four-point contact spherical slewing bearing is composed of two seat rings. It has compact structure, light weight, and four-point contact between steel ball and arc raceway. It can bear axial force, radial force and overturning moment at the same time. The construction machinery of rotary conveyor, welding manipulator, small and medium-sized crane and excavator can be selected.

轴承型号 Bearing type			外形尺寸 Boundary dimensions			安装孔尺寸 Mounting hole diameter			结构尺寸 Structure dimensions			齿轮参数 Gear parameters						质量 Mass kg		
无齿式 Non-gear type	外齿式 External gear type	内齿式 Internal gear type	D	dn	H	Du	Dn	n	φ	DL	H	b	m	外齿式 Ext gear			内齿式 Int gear			
			mm			mm			mm		mm	X		De mm	Z	X	de mm		Z	
HSB. 25. 625	HSW. 25. 625	HSN. 25. 625	725	525	80	685	565	18	18	3	625	12	60	5	+1.25	751.9	146	+0.35	498.8	101
	HSW. 25. 625A	HSN. 25. 625A												6	+1.00	755.5	122	+0.35	496.7	84
HSB. 25. 720	HSW. 25. 720	HSN. 25. 720	820	620	80	780	660	18	18	3	720	12	60	6	+1.25	860.3	139	+0.35	586.6	99
	HSW. 25. 720A	HSN. 25. 720A												8	+0.85	861.1	104	+0.35	582.3	74
HSB. 30. 820	HSW. 30. 820	HSN. 30. 820	940	705	95	893	749	24	20	4	820	12	70	6	+1.25	980.4	159	+0.35	664.5	112
	HSW. 30. 820A	HSN. 30. 820A												10	+0.85	986.2	95	+0.35	658	67
HSB. 30(32) . 880	HSW. 30(32) . 880	HSN. 30(32) . 880	1000	760	95	956	800	24	20	4	880	12	70	8	+1.0	1047.5	127	+0.35	718.2	91
	HSW. 30(32) . 880A	HSN. 30(32) . 880A												10	+0.85	1046.3	101	+0.35	707.9	72
HSB. 30(32) . 1020	HSW. 30(32) . 1020	HSN. 30(32) . 1020	1170	875	95	1120	930	24	22	4	1020	15	70	8	+1.25	1219.3	148	+0.35	830.1	105
	HSW. 30(32) . 1020A	HSN. 30(32) . 1020A												10	+1.00	1219.2	118	+0.35	827.8	84
HSB. 30(40) . 1220	HSW. 30(40) . 1220	HSN. 30(40) . 1220	1365	1075	120	1310	1130	36	24	6	1220	15	90	10	+1.25	1424.9	138	+0.35	1027.8	104
	HSW. 30(40) . 1220A	HSN. 30(40) . 1220A												12	+0.85	1435.9	116	+0.35	1017.3	86
HSB. 35(40) . 1250	HSW. 35(40) . 1250	HSN. 35(40) . 1250	1400	1090	120	1350	1150	36	26	6	1250	15	90	10	+0.35	1443	143	+0.35	1037	105
	HSW. 35(40) . 1250A	HSN. 35(40) . 1250A												12	+0.85	1449.6	117	+0.35	1028.8	87
HSB. 35(40) . 1435	HSW. 35(40) . 1435	HSN. 35(40) . 1435	1595	1278	120	1535	1335	36	26	6	1435	15	90	12	+1.0	1655.5	134	+0.35	1221.1	103
	HSW. 35(40) . 1435A	HSN. 35(40) . 1435A												14	+0.85	1661.2	115	+0.35	1214.8	88
HSB. 35(50) . 1540	HSW. 35(50) . 1540	HSN. 35(50) . 1540	1720	1360	140	1660	1420	42	26	6	1540	18	110	12	+1.4	1780.8	144	+0.35	1293.1	109
	HSW. 35(50) . 1540A	HSN. 35(50) . 1540A												14	+1.0	1791.1	124	+0.35	1284.8	93
HSB. 35(50) . 1700	HSW. 35(50) . 1700	HSN. 35(50) . 1700	1875	1525	140	1815	1585	42	29	6	1700	18	110	14	+1.0	1945.4	135	+0.35	1452.7	105
	HSW. 35(50) . 1700A	HSN. 35(50) . 1700A												16	+1.0	1950.8	118	+0.35	1452.3	92
HSB. 40(50) . 1880	HSW. 40(50) . 1880	HSN. 40(50) . 1880	2100	1665	160	2030	1740	48	32	6	1880	20	115	14	+1.25	2189.8	152	+0.35	1592.6	115
	HSW. 40(50) . 1880A	HSN. 40(50) . 1880A												18	+1.0	2194.6	118	+0.35	1579.9	89
HSB. 40(50) . 2115	HSW. 40(50) . 2115	HSN. 40(50) . 2115	2325	1900	160	2245	1980	48	32	6	2115	20	115	16	+1.25	2406.5	146	+0.35	1804.1	114
	HSW. 40(50) . 2115A	HSN. 40(50) . 2115A												20	+1.0	2418.4	117	+0.35	1795.4	91
HSB. 40(60) . 2370	HSW. 40(60) . 2370	HSN. 40(60) . 2370	2600	2146	180	2520	2220	48	32	6	2370	22	130	18	+1.25	2307.3	146	+0.35	2065.6	116
	HSW. 40(60) . 2370A	HSN. 40(60) . 2370A												22	+1.0	2704.4	119	+0.35	2040.9	94
HSB. 40(60) . 2600	HSW. 40(60) . 2600	HSN. 40(60) . 2600	2835	2365	180	2750	2450	54	36	6	2600	22	130	18	+1.25	2941.7	159	+0.35	2263.5	127
	HSW. 40(60) . 2600A	HSN. 40(60) . 2600A												22	+1.0	2946.9	130	+0.35	2260.8	104
HSB. 50(60) . 2820	HSW. 50(60) . 2820	HSN. 50(60) . 2820	3085	2555	200	3000	2640	54	36	6	2820	22	150	20	+1.25	3188.4	155	+0.35	2455	124
	HSW. 50(60) . 2820A	HSN. 50(60) . 2820A												25	+1.0	3198.4	124	+0.35	2444.1	99
HSB. 50(60) . 3120	HSW. 50(60) . 3120	HSN. 50(60) . 3120	3400	2840	200	3310	2930	54	36	6	3120	22	150	22	+1.25	3507.2	155	+0.35	2722	125
	HSW. 50(60) . 3120A	HSN. 50(60) . 3120A												25	+1.25	3509.6	136	+0.35	2719	110
HSB. 50(60) . 3580	HSW. 50(60) . 3580	HSN. 50(60) . 3580	3920	3240	240	3820	3340	60	40	6	3580	22	190	22	+1.25	4036.1	179	+0.35	3118.4	143
	HSW. 50(60) . 3580A	HSN. 50(60) . 3580A												25	+1.25	4035.6	157	+0.35	3118.8	126
HSB. 50(60) . 4030	HSW. 50(60) . 4030	HSN. 50(60) . 4030	4370	3690	240	4270	3790	66	40	6	4030	22	190	22	+1.25	4520.6	201	+0.35	3558.3	163
	HSW. 50(60) . 4030A	HSN. 50(60) . 4030A												28	+1.25	4522	157	+0.35	3549	128
HSB. 50(60) . 4540	HSW. 50(60) . 4540	HSN. 50(60) . 4540	4860	4210	240	4760	4310	72	40	6	4540	22	190	22	+1.25	4983	222	+0.35	4042.2	185
	HSW. 50(60) . 4540A	HSN. 50(60) . 4540A												30	+1.25	4992.9	162	+0.35	4042.4	136

回转支承类型和系列三

Types and series three of slewing bearings

《JB/T10839-2008》标准回转支承编号方法:

JB/T10839-2008 standard slewing bearing numbering method

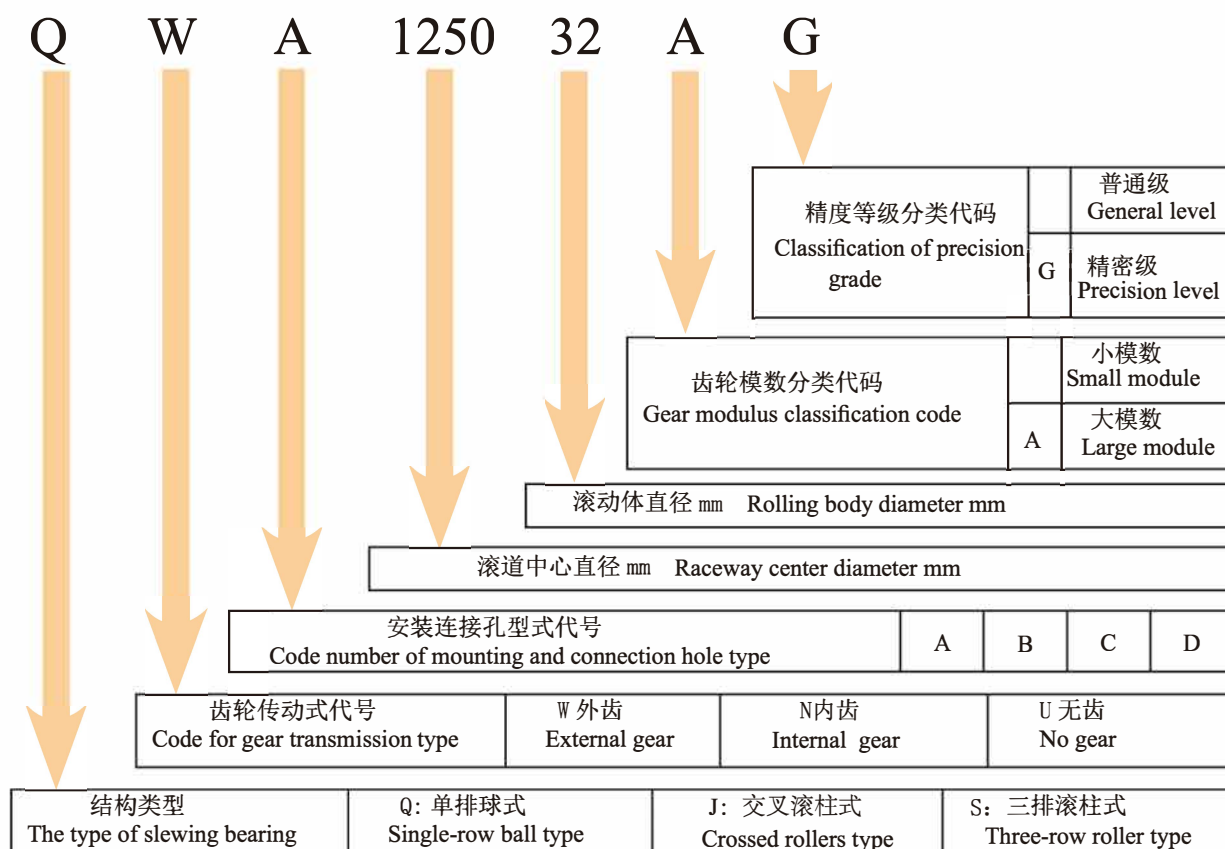

说明: 1. 无齿式 (QU) 系列外形尺寸由相同滚道中心直径的内齿式 D 和外齿式 d_n 组成, 其堵塞与油孔布置在外圈上;
Explanation: 1. The dimensions of the No gear (QU) series are composed of Internal gear D and External gear d_n with the same raceway center diameter, and The plug position and oil holes are arranged on the outer ring.

2. 安装连接孔型式代号

Mounting and connection hole type code

A: 内、外套圈均为光孔

Inner and outer rings are unthreaded holes.

B: 内、外套圈基面均为螺纹孔, 深度为 T (安装孔螺纹 T 可在孔的另一端)

The base of the inner and outer rings are threaded holes with a depth of T (the mounting hole thread T can be at the other end of the hole).

C: 外套圈基面螺纹孔, 深度为 T, 内套圈为光孔 (安装孔螺纹 T 可在孔的另一端)

The base of outer rings is threaded holes with a depth of T, the inner ring is the unthreaded hole (the mounting hole thread T can be at the other end of the hole).

D: 内套圈基面螺纹孔, 深度为 T, 外套圈为光孔 (安装孔螺纹 T 可在孔的另一端)

The base of inner ring is threaded holes with a depth of T, the outer rings is the unthreaded hole (the mounting hole thread T can be at the other end of the hole).

3. 外齿式 (QW) 结构图、内齿式 (QN) 结构图和无齿式 (QU) 结构图如下:

The External gear type (QW) structure diagram, the Internal gear type (QN) structure diagram and the No gear (QU) structure diagram are as follows:

Q 系列

单排四点接触球回转支承 (Q 系列)

Single row four point contact ball slewing bearing (Q series)

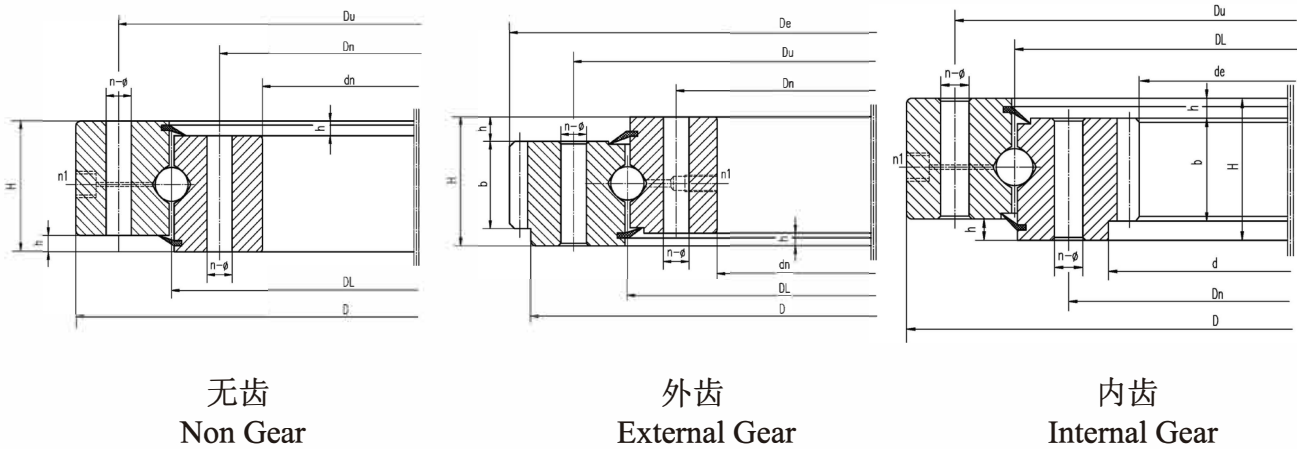

结构特点、性能、适用范围

单排四点接触球式回转支承由两个座圈组成, 结构紧凑, 重量轻, 钢球与圆弧滚道四点接触, 能同时承受轴向力, 径向力和倾翻力矩, 回转式输送机, 焊接操作机, 中小型起重机和挖掘机等工程机械均可选用。

Structural characteristics, performance and scope of application

The single row four point contact ball slewing bearing is composed of two seat rings, which design in compact structure and light weight, steel ball contact with the circular raceway at four point, it can bear the axial force, radial force and the tilting moment at the same time. It can be used for slewing conveyer, welding manipulator, light & ledium duty crane, excavator and other construction machinery.

轴承型号 Bearing type	外形尺寸 Boundary dimensions				安装孔尺寸 Mounting hole diameter							结构尺寸 Structure dimensions			齿轮参数 Gear parameters						
	外齿式 External gear type		内齿式 Internal gear type		H	Du	Dn	n	通孔 Through hole A型	螺孔 Screw holes B, C, D型		n1 油杯 数量 Number of oil holes	h	b	m 模数 Modulus	外齿式 External gear type			内齿式 Internal gear type		
	D	dn	D	d					φ	d1	T					x=-0.5			x=+0.5		
	mm				mm			mm			mm	mm	mm	kg	mm	mm	kg				
280.16	360	198	360	200	60	328	232	10	15	M14	28	2	10	44	3.5	385	109	29	178.5	52	27
280.16A															4	388	96	29	176	45	27
315.16	395	233	397	235	60	363	267	12	15	M14	28	2	10	44	3.5	423.5	120	34	213.5	62	31
315.16A															4	424	105	34	212	54	31
355.16	435	273	437	275	60	403	307	12	15	M14	28	2	10	44	3.5	458.5	131	37	252	73	34
355.16A															4	460	115	38	252	64	34
400.16	480	318	482	320	60	448	352	12	15	M14	28	2	10	44	3.5	504	143	45	297.5	86	42
400.16A															4	504	125	46	296	75	43
450.16	530	368	532	370	60	498	402	12	15	M14	28	2	10	44	3.5	553	157	51	346.5	100	50
450.16A															4	556	138	52	344	87	51
450.20	544	354	546	354	70	508	392	12	17	M16	30	2	10	50	4	572	142	65	328	83	62
450.20A															5	570	113	64	325	66	62
500.20	594	404	596	404	70	558	442	14	17	M16	30	2	10	50	4	624	155	74	376	95	70
500.20A															5	625	124	74	375	76	70
560.20	654	464	656	468	70	618	502	14	17	M16	30	2	10	50	4	680	169	78	440	111	76
560.20A															5	685	136	79	435	88	77
630.20	724	534	726	538	70	688	572	16	17	M16	30	2	10	50	4	748	186	86	512	129	84
630.20A															5	755	150	88	505	102	86
710.20	804	614	806	618	70	768	652	18	17	M16	30	2	10	50	5	835	166	99	585	118	97
710.20A															6	840	139	101	582	98	97
800.20	894	704	896	708	70	858	742	20	17	M16	30	2	10	50	6	930	154	114	672	113	110
800.20A															8	936	116	114	664	84	111
630.25	734	522	738	522	78	694	566	16	22	M20	36	2	10	58	5	770	153	113	490	99	107
630.25A															6	774	128	114	486	82	107
710.25	814	602	818	602	78	774	646	18	17	M20	36	2	10	58	6	858	142	131	564	95	122
710.25A															8	864	107	132	560	71	122
800.25	904	692	908	694	78	864	736	18	22	M20	36	2	10	58	6	942	156	143	654	110	142
800.25A															8	952	118	147	648	82	142
900.25	1004	792	1008	794	78	964	836	20	22	M20	36	2	10	58	8	1048	130	162	744	94	163
900.25A															10	1060	105	168	740	75	162
1000.25	1104	892	1108	894	78	1064	936	24	22	M20	36	2	10	58	8	1152	143	182	848	107	178
1000.25A															10	1160	115	185	840	85	179
1120.25	1124	1012	1228	1014	78	1184	1056	28	22	M20	36	2	10	58	8	1280	159	213	968	122	197
1120.25A															10	1280	127	210	960	97	201

轴承型号 Bearing type	外形尺寸 Boundary dimensions				安装孔尺寸 Mounting hole diameter							结构尺寸 Structure dimensions			齿轮参数 Gear parameters								
	外齿式 External gear type		内齿式 Internal gear type		H	Du	Dn	n	通孔 Through hole A型	螺孔 Screw holes B, C, D型		n1 油杯 数量 Number of oil holes	h	b	m 模数 Modulus	外齿式 External gear type			内齿式 Internal gear type				
	D	dn	D	d					φ	d1	T					x=-0.5		x=+0.5					
					De	Z	质量 Mass	de				Z	质量 Mass										
	mm				mm			mm			mm	mm		mm	mm	mm	mm	mm	mm	mm	mm	kg	kg
800.32	920	676	924	680	90	874	726	18	24	M22	40	2	10	70	8	976	121	211	632	80	196		
800.32A															10	980	97	212	630	64	195		
900.32	1020	776	1024	780	90	974	826	20	24	M22	40	2	10	70	8	1072	133	235	720	91	229		
900.32A															10	1080	107	239	720	73	227		
1000.32	1120	876	1124	880	90	1074	926	24	24	M22	40	2	10	70	8	1160	144	227	832	105	230		
1000.32A															10	1170	116	232	830	84	227		
1120.32	1240	996	1244	1000	90	1194	1046	28	24	M22	40	4	10	70	10	1300	129	272	940	95	263		
1120.32A															12	1308	108	275	936	79	262		
1250.32	1370	1126	1374	1130	90	1324	1176	32	24	M22	40	4	10	70	10	1430	142	302	1070	108	294		
1250.32A															12	1440	119	309	1068	90	290		
1400.32	1520	1276	1524	1280	90	1474	1326	36	24	M22	40	4	10	70	12	1584	131	337	1212	102	333		
1400.32A															14	1596	113	347	1204	87	336		
900.40	1040	758	1044	760	102	986	814	20	26	M24	45	4	12	80	10	1100	109	304	700	71	288		
900.40A															12	1104	91	305	696	59	289		
1000.40	1140	858	1144	860	102	1086	914	24	26	M24	45	4	12	80	10	1200	119	336	800	81	321		
1000.40A															12	1212	100	347	792	67	324		
1120.40	1260	978	1264	980	102	1206	1034	282	26	M24	45	4	12	80	10	1320	131	374	920	93	359		
1120.40A															12	1332	110	386	912	77	363		
1250.40	1390	1108	1394	1110	102	1336	1164	32	26	M24	45	4	12	80	10	1450	144	396	1050	106	388		
1250.40A															12	1452	120	392	1044	88	388		
1400.40	1540	1258	1544	1260	102	1486	1314	36	26	M24	45	4	12	80	12	1608	133	448	1188	100	444		
1400.40A															14	1610	114	443	1190	86	434		
1600.40	1740	1458	1744	1460	102	1686	1514	40	26	M24	45	4	12	80	12	1812	150	528	1392	117	509		
1600.40A															14	1820	129	534	1386	100	511		
1800.40	1940	1658	1944	1660	102	1886	1714	44	26	M24	45	4	12	80	14	2016	143	583	1582	114	576		
1800.40A															16	2032	126	607	1568	99	591		
2000.40	2140	1858	2144	1960	102	2086	1914	48	26	M24	45	4	12	80	14	2226	158	714	1778	128	675		
2000.40A															16	2224	138	727	1776	112	673		
1250.50	1412	1084	1416	1088	124	1354	1146	32	30	M27	50	4	12	100	12	1476	122	583	1008	85	581		
1250.50A															14	1484	105	592	1008	73	577		
1400.50	1562	1234	1566	1238	124	1504	1296	36	30	M27	50	4	12	100	12	1632	135	665	1164	98	645		
1400.50A															14	1638	116	670	1162	84	643		
1600.50	1762	1434	1766	1438	124	1704	1496	40	30	M27	50	4	12	100	12	1824	151	714	1368	115	714		
1600.50A															14	1834	130	727	1358	98	723		

轴承型号 Bearing type	外形尺寸 Boundary dimensions				安装孔尺寸 Mounting hole diameter						结构尺寸 Structure dimensions			齿轮参数 Gear parameters								
	外齿式 External gear type		内齿式 Internal gear type		H	Du	Dn	n	通孔 Through hole A型		螺孔 Screw holes B, C, D型		n1 油杯数量 Number of oil holes	h	b	m 模数 Modulus	外齿式 External gear type			内齿式 Internal gear type		
	D	dn	D	d					Φ	d1	T	x=-0.5					x=+0.5					
					De	Z	质量 Mass	de				Z	质量 Mass									
mm				mm			mm			mm	mm			mm	kg		mm	kg				
1800.50	1962	1634	1966	1638	124	1904	1696	44	30	M27	50	4	12	100	14	2044	145	845	1568	113	794	
1800.50A																16	2048	127	843	1552	98	818
2000.50	2162	1834	2166	1842	124	2104	1896	48	30	M27	50	6	12	100	16	2240	139	912	1760	111	891	
2000.50A																18	2250	124	927	1746	98	913
2240.50	2402	2074	2406	2078	124	2344	2136	54	30	M27	50	6	12	100	16	2480	154	1020	1984	125	1044	
2240.50A																18	2502	138	1078	1980	111	1041
2500.50	2662	2334	2666	2342	124	2604	2396	60	30	M27	50	6	12	100	18	2754	152	1171	2250	126	1132	
2500.50A																20	2760	137	1175	2240	113	1148
2800.50	2962	2634	2966	2638	124	2904	2696	66	30	M27	50	6	12	100	18	3060	169	1393	2538	142	1361	
2800.50A																20	3060	152	1382	2540	128	1344
3150.50	3312	2984	3316	2988	124	3254	3046	72	30	M27	50	6	12	100	18	3402	188	1535	2898	162	1501	
3150.50A																20	3420	170	1597	2880	145	1554
2000.60	2196	1804	2196	1808	150	2126	1874	48	33	M30	56	6	14	122	18	2304	127	1431	1710	96	1344	
2000.60A																20	2320	115	1476	1700	86	1361
2240.60	2436	2044	2436	2048	150	2366	2114	54	33	M30	56	6	14	122	18	2538	140	1576	1944	109	1526	
2240.60A																20	2540	126	1572	1940	98	1527
2500.60	2696	2304	2696	2308	150	2626	2374	60	33	M30	56	6	14	122	18	2790	154	1677	2214	124	1621	
2500.60A																20	2800	139	1701	2200	111	1654
2800.60	2992	2604	2996	2608	150	2926	2674	66	33	M30	56	6	14	122	18	3078	170	1817	2502	140	1871	
2800.60A																20	3100	154	1904	2500	126	1857
3150.60	3342	2954	3346	2958	150	3276	3024	72	33	M30	56	6	14	122	20	3440	171	2087	2840	143	2144	
3150.60A																22	3454	156	2139	2838	130	2129
3550.60	3742	2354	3746	3358	150	3676	3424	78	33	M30	56	6	14	122	20	3840	191	2355	3240	163	2425	
3550.60A																25	3875	154	2500	3225	130	2437
4000.60	4200	3804	4196	3808	150	4126	3874	80	33	M30	56	6	14	122	22	4312	195	2787	3696	169	2683	
4000.60A																25	4325	172	2827	3675	148	2763
4500.60	4700	4304	3316	2988	150	4626	4374	86	33	M30	56	6	14	122	25	4825	192	3268	4175	168	3247	
4500.60A																28	4816	172	3372	4172	150	3334

回转支承类型和系列四

Types and series four of slewing bearings

本代号方法是沿用原国家标准轴承代号方法。由前置代号，基本代号和后置代号组成
 This designation method follows the previous China national bearing standard. It consists of prefix code, basic code and suffix code.

1. 前置代号:

回转支承精度等级分为 G, E, D 三级，一般普通级 G 可以不标注。

1. Prefix Code

The precision grade of slewing bearing has three grades: Grade G, Grade E, Grade D, Grade G is generally the standard specification and not normally shown.

2. 基本代号:

基本代号由七位阿拉伯数字组成，数字代表的意义见下表

2. Basic Code

The basic code consists of 7 numbers, the explanation for these numbers are referred to in the table below

轴承内径 d Inner diameter d (mm)	代号方法 Designation method	示例 Examples	
		轴承型号 Bearing type	内径 (mm) Inner diameter (mm)
< 500	1. 内径除以5之商数表示 Expressed by the quotient of dividing inner diameter by 5. 2. 内径为小数或者不能被5整除时，用分数表示，分母直接表示内径尺寸 When the inner diameter is decimal or could not be divided exactly by 5, it will be expressed by a fraction, and the denominator directly indicates the dimension of inner diameter	79764	320
		797/496	496
		797/488.5	488.5
≥ 500	用分数表示 分母直接表示内径尺寸 Expressed by fraction, and the denominator directly indicates the dimension of inner diameter	797/800	800

3. 后置代号: 回转支承常用的后置代号见表

3. Suffix Code: Common suffix codes used in slewing bearing designations are shown in the table below

符号 Code	定义 Definition
G, G2, ...	其中:G表示套圈材料为5CrMnMo: In which:G indicates the material of bearing ring is 5CrMnMo: G2表示套圈材料为50Mn: 无代号时套圈材料为42CrMo G2 indicates the material of bearing rings is 50Mn: the material of bearing ring is 42CrMo, when there is no code.
K, K1, K2...	轴承结构与标准结构有差异 Bearing structure differs from the standard structure.
M	有摩擦力矩要求的 Requirement for friction moment
Y, Y1, Y2...	轴承技术有变化 Changes in bearing technique

示例:

E (0) 17 9 2 885 G2 K

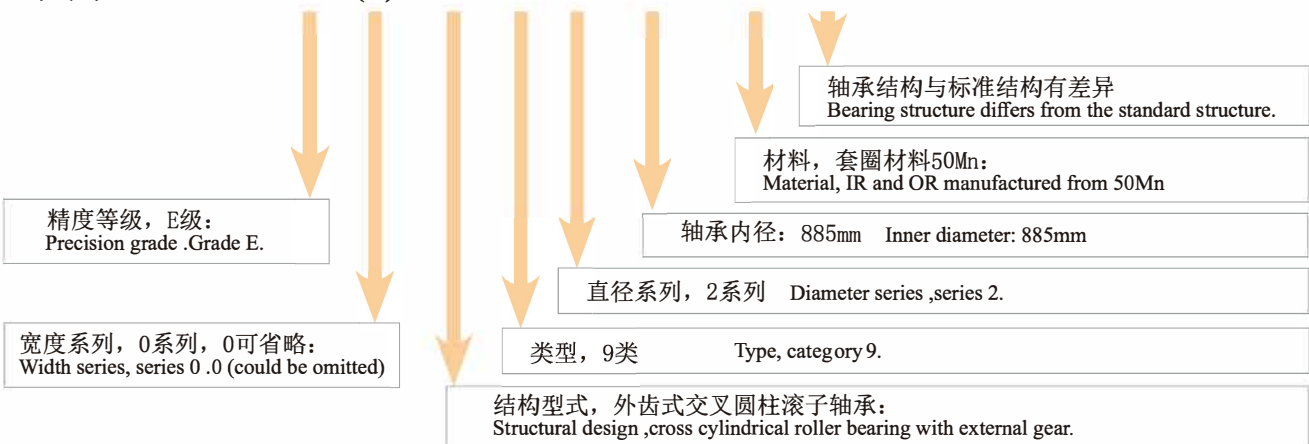

单排交叉滚柱式回转支承 (797 系列)
Single row cross roller slewing bearing (797 series)

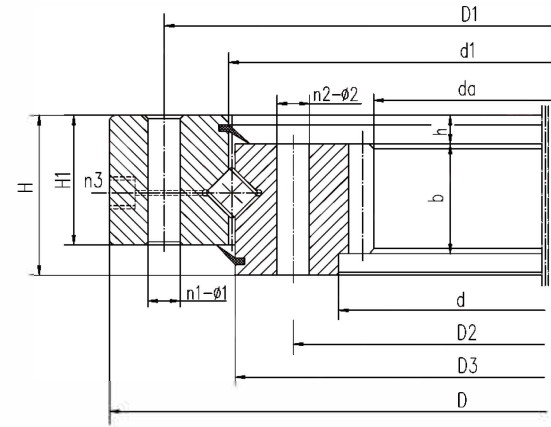

内齿
Internal Gear

轴承型号 Bearing type	外形尺寸 Boundary dimensions			安装孔尺寸 Mounting hole diameter						结构尺寸 Structure dimensions						齿轮参数 Gear parameters					质量 Mass kg
	D	d	H	D1	D2	n1	n2	φ1 mm	φ2 mm	D3	d1	H1	h	n3	φ3 mm	m	da mm	Z	b mm	X	
2797/760G2	1000	760	95	956	800	24	24	20	20	878	882	82	15	4	M10X1	8	718	91	70	0.35	206
2797/870G2	1180	870	115	1125	920	18	18	26	26	1023	1027	100	15	2	M8x1	8	828.8	105	90	0.3	374
2797/875G2	1170	875	95	1120	930	24	24	22	22	1018	1022	82	10	4	M10X1	8	830	105	70	0.35	297
2797/955G2	1200	955	90	1160	1000	36	18	18	18	1088	1092	76	10	4	M8x1	8	908	115	72	0.3	245
2797/1010G2	1200	1010	90	1160	1041	36	20	22	M20	1088	1092	76	10	2	M8x1	10	962	97	72	0.6	199
2797/1010GK	1200	1010	90	1160	1041	36	20	22	M20	1088	1092	76	10	2	M8x1	10	962	97	72	0.6	199
1278/2797G2	1595	1278	120	1535	1335	36	36	26	26	1428	1432	106	14	6	M10X1	12	1221	103	90	0.35	585
2797/1400G2K	1715	1400	110	1660	1460	40	40	26	M24	1558	1562	95	15	4	M10X1	10	1330	135	90	0	587
2797/2000G2	2420	2000	160	2350	2070	48	48	33	M30	2207	2213	140	20	6	M10X1	14	1913	138	120	0.3	1607
2797/2240G	2670	2240	160	2600	2320	54	54	35	M36	2457	2463	140	20	6	M12X1.25	16	2154.5	136	120	0.3	1798
3-940G	2800	2300	208	2710	2390	42	48	38	M36	2535	2545	180	18	6	M10X1	20	2162.75	110	175	0	2756
2797/2680G	3325	2680	300	3242	2754	32	32	33	33	2996	3000	270	30	4	M16X1.5	16	2592	164	180	0	6320
2797/2680GY	3325	2680	300	3242	2754	48	48	33	33	2996	3000	270	30	4	M16X1.5	16	2592	164	180	0	6320
2797/2680GK	3325	2680	300	3242	2754	32	32	33	33	2996	3000	270	30	4	M16X1.5	16	2592	164	180	0	6641
3-943G2	3850	3322	200	3720	3420	60	60	45	45	3568	3572	180	20	12	Z1/4in	22	3206	147	158	0.35	4520

797 系列

恒久专注 冠军品质

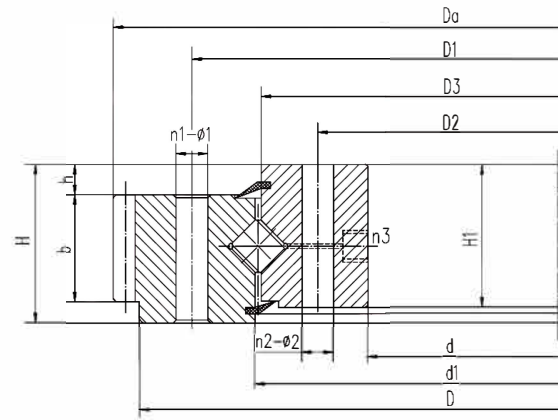

外齿
External Gear

轴承型号 Bearing type	外形尺寸 Boundary dimensions			安装孔尺寸 Mounting hole diameter						结构尺寸 Structure dimensions							齿轮参数 Gear parameters					质量 Mass kg
	D	d	H	D1	D2	n1	n2	φ 1 mm	φ 2 mm	D3	d1	H1	h	n3	φ 3 mm	m	Da mm	Z	b mm	X		
1792/885	1056	885	83	1032	925	16	16	M16	17.5	986	988	75	12.5			8	1096	135	62.5	0	172	
E1792/885	1056	885	83	1032	925	16	16	M16	17.5	986	988	75	12.5			8	1096	135	62.5	0	172	
E1792/885K	1056	885	83	1032	925	16	16	M16	17.5	986	988	75	12.5	3	M10X1	8	1096	135	62.5	0	172	
1797/885G	1150	885	115	1115	935	16	16	18	18	1023	1027	100	15	4	M8x1	5	1180	234	80	0	330	
1797/1100G	1415	1100	115	1345	1160	24	18	21	21	1253	1255	100	15	4	M12X1.25	6	1452	240	84	0	497	
1798/1100G2	1400	1100	140	1352	1160	26	26	24	26	1260	1264	126	21	4	M10X1	14	1477.28	104	90	-0.24	642	
1798/1100G2K	1400	1100	145	1352	1160	26	26	24	26	1260	1264	131	26	4	M10X1	14	1477.28	104	90	-0.24	644	
1797/1250G2	1548	1250	148	1512	1297	16	16	25	25	1403	1407	122	20	4	M10X1	12	1608	132	100	0	661	
1797/1278G2	1595	1278	120	1535	1335	36	36	26	26	1428	1432	105	15	4	M10X1	12	1655.46	134	90	1.15	597	
1797/1300G2	1705	1300	165	1644	1360	24	24	32	32	1504	1508	134	31	4	M10X1	14	1783.6	126	85	-0.3	1023	
1792/1400G	1715	1400	110	1660	1460	42	42	26	26	1558	1562	95	17	4	M12X1.25	12	1780.8	147	78	-0.3	597	
1792/1400G2	1715	1400	110	1660	1460	42	42	26	26	1558	1562	95	17	4	M12X1.25	12	1881.6	147	78	-0.3	597	
1792/1400G2K	1715	1400	110	1660	1460	42	42	26	26	1558	1562	95	17	4	M12X1.25	12	1780.8	147	78	-0.3	597	

轴承型号 Bearing type	外形尺寸 Boundary dimensions			安装孔尺寸 Mounting hole diameter						结构尺寸 Structure dimensions						齿轮参数 Gear parameters					质量 Mass kg
	D	d	H	D1	D2	n1	n2	$\phi 1$	$\phi 2$	D3	d1	H1	h	n3	$\phi 3$	m	Da	Z	b	X	
								mm	mm								mm		mm		
1797/1460G2	1800	1460	125	1735	1525	32	36	26	26	1633	1637	110	10	4	M10X1	14	1881.6	133	95	-0.3	828
1797/1460G2K		1460	125	1735	1525	32	36	26	26	1633	1637	110	10	4	M10X1	10	1880	186	115	0	845
1797/1916G2		1916	150	2245	1980	42	42	34	34	2113	2117	130	15	3	M10X1	18	2415.6	133	135	-0.4	1597
1797/2100G2	2600	2100	180	2540	2200	48	48	32	32	2368	2372	158	22	8	M10X1	18	2700	148	130	0	2395
1797/2100G2K	2600	2100	180	2540	2200	48	48	32	32	2368	2372	158	22	8	M10X1	18	2700	148	130	0	2392
1797/2460G2		2460	220	2930	2560	30	30	33	34	2785		185	20	30	M12X1.25	14	3108	220	200	0	4091
1797/2460G2U		2460	220	2930	2560	30	30	33	34	2745	2747	185	20	30	M12X1.25	14	3108	220	200	0	4091
1797/2460G2K		2460	220	2930	2560	30	30	33	34	2875		185	35	15	ZG1/4in	14	3108	220	200	0	4091
1797/2460G2K1		2460	220	2930	2560	30	30	33	34	2875		185	35	30	ZG1/4in	14	3108	220	200	0	4091
1797/2500G2		2500	210	2990	2630	36	36	37	37	2818	2822	200	10	12	M14X1.5	25	3250	128	200	0	4597
1797/2500K	2920	2500	260	3060	2622	36	36	40	40	2949	2916	240	60	36	ZG1/4in	18	3258	179	190	0	5407
1797/2500G2K1	2920	2500	260	3060	2622	36	36	40	40	2949	2916	240	60	36	ZG1/4in	18	3258	179	190	0	5407
1797/2600G		2600	200	3050	2700	60	60	35	35	2868	2872	180	20	6	M12X1.25	20	3232.8	160	180	-0.18	3936
1797/2600G2		2600	200	3050	2700	60	60	35	35	2868	2872	180	20	6	ZG1/4in	20	3232.8	160	180	-0.18	3936
1797/2600G2K		2600	200	3050	2700	60	60	35	35	2868	2872	180	20	4	14	20	3232.8	160	180	-0.18	3936
1797/2600G2K1		2600	200	3050	2700	60	60	35	35	2868	2872	180	20	8	M10X1	20	3232.8	160	180	-0.18	3936
1797/2635G	3332	2635	270	3240	2755	36	36	42	42	2998	3002	240	45	6	M12X1.25	20	3440	170	200	0	5937
1797/2635G	3332	2635	270	3240	2755	36	36	42	42	2998	3002	225	30	12	ZG1/4in	20	3440	170	200	0	5937
1797/3230G	3970	3230	240	3820	3350	52	54	37	37	3578	3582	220	20	9	M12X1.25	25	4100	162	200	0	7612
1797/3230GY	3970	3230	240	3820	3380	52	36	37	37	3578	3582	220	20	4	M12X1.25	25	4100	162	200	0	7612
1797/3230G2	3970	3230	240	3820	3350	52	54	37	37	3578	3582	220	20	9	M12X1.25	25	4100	162	200	0	7613
1797/3230G2K	3970	3230	240	3820	3350	52	54	37	37	3578	3582	220	20	8	14	25	4100	162	200	0	7613
1797/3230G2K2	3970	3230	240	3820	3350	52	54	37	37	3578	3582	220	20	18	M12X1.25	22	4092	184	200	0	7804
1797/3230G2K3	3940	3230	240	3820	3350	52	54	37	37	3578	3582	220	20	9	M12X1.25	20	4080	202	200	0	7302
1797/3230G2Y	3970	3230	240	3820	3380	52	36	37	37	3578	3582	220	20	4	M12X1.25	25	4100	162	200	0	7613
1797/3230G2Y2	3970	3230	240	3820	3380	52	36	37	37	3578	3582	220	20	4	M12X1.25	25	4100	162	200	0	7613
1797/3230G2Y3		3230	240	3820	3380	52	36	37	37	3578	3582	220	20	4	M14X1.5	25	4100	162	220	0	7686
1797/3230GK4	3970	3230	240	3820	3380	52	68	37	37	3578	3582	220	20	18	M14X1.5	25	4100	162	200	0	7613
1797/3230GK5	3970	3230	240	3820	3350	52	54	37	37	3578	3582	220	20	4	M12X1.25	25	4100	162	200	0	7613
1797/3230G2Y3K		3230	240	3820	3380	52	36	37	37	3578	3582	220	20	4	M12X1.25	25	4100	162	220	0	7686
1797/3760G	4220	3760	240	4160	3840	48	48	32	32	3996	4004	210	55	4	M14X1.5	14	4326	307	135	0	8246
1797/4250G	4940	4250	250	4840	4350	72	72	48	48	4598	4602	225	25	9	M16X1.5	30	5082	168	200	-0.3	8654

无齿
Non Gear

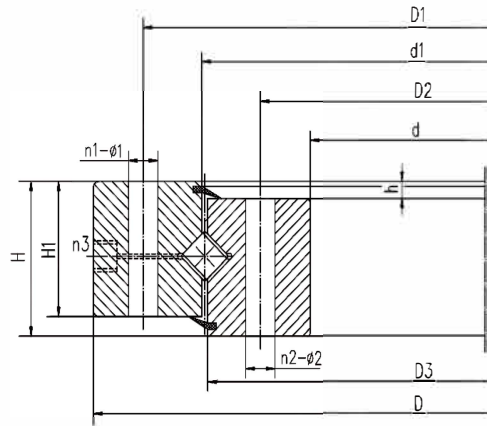

轴承型号 Bearing type	外形尺寸 Boundary dimensions			安装孔尺寸 Mounting hole diameter						结构尺寸 Structure dimensions						质量 Mass kg
	D	d	H	D1	D2	n1	n2	φ 1 mm	φ 2 mm	D3	d1	H1	h	n3	φ 3 mm	
无齿式 Non gear type	mm			mm				mm	mm	mm						
79764	550	320	85	515	365	12	8	17	18	438	442	75	10	-	-	85.6
797/600G2	900	600	125	848	690	30	29	26	M24	750	754	105	15	3	M10X1	246
797/670	907	670	85	870	730	12	8	M16	18	808	812	75	10	-	-	170
797/700G	1000	700	140	940	770	24	24	M20	22	879	882	130	20	4	M10X1	370
797/845G2	1150	845	130	1100	895	24	24	22	22	1024	1030	105	10	6	M6	393
797/870G	1180	870	115	1125	920	18	18	28	28	1023	1027	100	15	2	M8x1	355
797/870K	1180	870	115	1125	920	18	18	28	28	1023	1027	100	15	2	M10X1	355
797/870G2K1	1180	870	115	1125	920	18	18	28	28	1023	1027	100	15	2	M10X1	355
797/962G2	1200	962	90	-	-	-	-	-	-	1088	1092	76	10	-	-	224
792/1000G2	1270	1000	100	1220	1050	36	36	19	19	1132	1138	85	15	4	M10X1	303
792/1000G2K	1270	1000	100	1220	1050	36	36	19	19	1132	1138	85	15	3	9	303
792/1000G2K1	1270	1000	100	1220	1050	36	36	19	19	1132	1138	85	15	-	-	303
792/1000G2K2	1270	1000	100	1220	1050	36	36	19	19	1132	1138	85	15	-	-	303
797/1060G2	1400	1060	120	-	-	-	-	-	-	1248	1252	120	-	-	-	596
797/1200G2	1520	1200	90	-	-	-	-	-	-	1356	1364	90	-	-	-	504
792/1250G2	1700	1250	155	1650	1330	24	24	26	26	1446	1450	140	10	6	M10X1	1103
797/1250G2	1608	1250	148	1512	1297	16	16	25	25	1403	1047	128	26	4	M10X1	743
797/1250G2K	1608	1250	148	1512	1297	16	16	25	25	1403	1047	128	26	4	M10X1	717
797/1278G2K	1660	1278	120	1535	1335	18	18	26	26	1428	1432	105	15	4	M10X1	589
797/1320G2	1715	1320	134	1337	1163		40			1503	1509	-	-	-	-	958
797/1370G	1840	1370	160	1770	1430	30	24	28	28	1598	1602	140	10	4	M10X1	1213
797/1380G2	1700	1380	145	1650	1440	24	24	27	27	1568	1574	140	5	6	M10X1	746
3-944G2	1680	1412	170	-	1460	-	24	-	18	1544	1548	120	25	2	M10X1	725
3-944G2K	1680	1412	170	-	1460	-	24	-	18	1544	1548	120	25	2	M10X1	723
3-944G2K1	1680	1412	185	-	1460	-	24	-	18	1544	1548	120	25	2	M12X1.25	759
797/1600G	2140	1600	145	1940	1710	48	48	26	26	1828	1832	135	10	4	M10X1	1357
797/1776G2	2210	1776	150	2105	1840	36	36	26	26	1968	1972	135	15	4	M10X1	1244
797/1860G2	2320	1860	151	2245	1980	42	42	33	33	2113	2117	150	10	6	M10X1	1772
797/1916G2	2320	1916	150	2245	1980	42	42	34	34	2113	2117	130	20	3	M10X1	1214
797/2190G	2860	2190	300	2800	2270	36	36	32	32	2530	2550	260	40	12	8	4797
797/2500G2	2980	2500	180	2910	2590	48	48	33	33	2739	2743	170	10	6	M16X1.5	2913
792/2800G	3310	2800	190	3220	2890	60	60	39	39	3050	3060	165	25	2	M10X1	2864

回转支承的安装与保养

Slewing Bearing Installation and Maintenance

一、防锈、包装与运输

Anti-rust,packing,transportation

1) 防锈和包装

Anti-rust & Packing

回转支承内、外表面均涂有防锈润滑两用油，如有特殊要求的按技术协议加注相应油脂，包装采用塑料薄膜、塑料编织带等缠绕包装。有特别要求的，可根据需求个性化包装。

Slewing bearing painted by anti-rust oil and lubrication inside&outside,packed by film,brown paper,plastic knit bag.If have special demand,can personalized packing according to the demand

2) 运输

Transportation

在运输期间尽可能使产品水平放置，仅允许产品稍微倾斜、震动，应避免碰撞和雨淋。当不用木箱包装时，要用三块以上的木垫块将产品与汽车底板隔开且放平，以免擦伤回转支承端面。打开包装后，用吊装螺栓拧在内圈或外圈的吊装孔内，水平将轴承搬运到安装位置，两吊索间的夹角不大于 120° ，以免损伤回转支承，确保安全（图 1-1）。

Bearings place while transportation,allow to place bearings a bit inclination avoid hit and rain.If transporting bearings without packing by wooden cases,more than three wooden cushion blocks shall be used to separate the product from the vehicle floor and place it flat.After opening the package,use the transport bolts to screw the hole of inner ring or outer ring,hang up the bearings on level to the mounting place,the angle between the 2 slings is not more than 120° ,so as not to damage the slewing bearing and ensure safety (Picture 1-1).

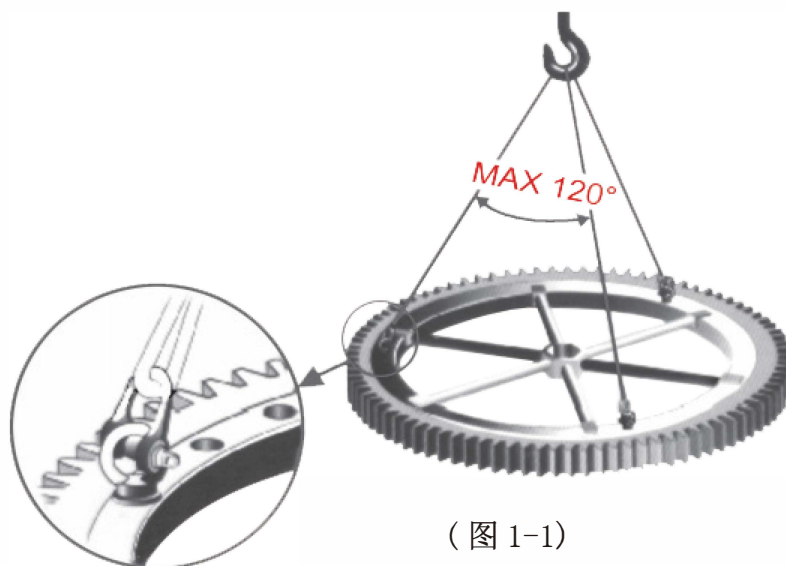

(图 1-1)

二、保管

Storage

1) 防锈期（轴承从出厂后 12 个月）请勿打开包装。超出防锈期后维护和保养应及时，回转支承滚道、外表面、齿面均应进行防锈处理。外表面擦洗干净，均匀涂上一层防锈油脂，轴承内腔注入适用油脂（参考第 8 条）。

Anti-rust period(within 12 months after bearing ex-factory),if need maintenance,should have anti-rust treatment to the raceway,surface,gear surface,clear the surface and paint anti-rust grease or industrial Vaseline,fill No.2 pole lithium grease in inner raceway.

2) 在干燥平坦的场地上水平放置回转支承，禁止回转支承直接接触地面和在阳光下暴晒，注意远离水管、蒸汽管、防止雨淋、以免锈蚀。如果多套回转支承叠放在一起时，每套回转支承之间沿圆周方向至少放置三个均布的木垫块，且上、下层垫块位置应放置一致（图 2-1）。

Place the slewing bearing on level at dry and plain site to prohibit the slewing bearing contact the ground under direct sunlight,keep far away from water pipe,steam pipe to avoid bearings corrosion,if many slewing bearings pile up together,each slewing bearing place at least 3 equal wooden mats around circle position,the position up and down show be the same(Picture 2-1).

3) 如果回转支承贮藏时间长于 12 个月，应重新防锈。

3) If the slewing bearings storage over 12 months,should anti-rust again.

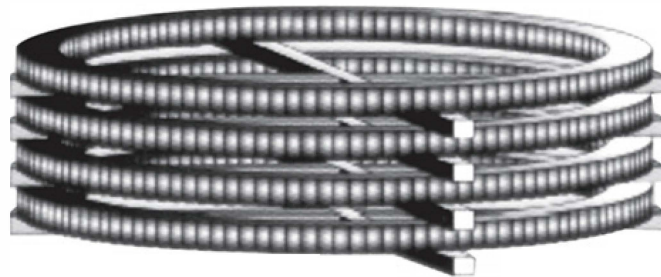

(图 2-1)

三、安装前注意

Notice before mounting

1) 轴承拆开包装，请注意检查产品合格证，核对产品型号、编号，确认收到的产品与合同订单一致。

Before unpacking the bearing,please check product certificate,product type,serial number,make sure to received the same products with the contract order.

2) 产品型号标牌，位于外圈外径或内圈内径的非齿面上。

Product type label,on the non-gear face outer dia of outer ring or inner dia of inner ring.

3) 轴承滚道表面淬火是不封闭的，淬火连接处是一软带区，在轴承相对应端面上加“S”标识；此区域属于非淬火区。

Quench on surface of bearing raceway are not closed,quench connection is soft zone on bearing side face that marks”S”as non-quench area.

4) 确认收到的产品在运输途中或存放过程中没有受到锈蚀、碰伤和损坏。

Make sure to received products without corrosion,wound,damage.

5) 确认密封圈没有损坏，否则更换密封圈，并检查轴承回转是否灵活。

Make sure that sealing no damage otherwise exchange seals,check bearing rotation agility.

6) 清洗轴承安装表面的防锈油，注意清洗时不要让清洗剂进入轴承滚道中。

Clear the surface grease of mounting bearing,cleanser can not come into bearing raceway while clearing.

7) 严禁私自解体回转支承，移动内部零件。

Forbid to disassemble bearings,move inner parts privately.

齿圈齿表面三个相邻齿如涂有绿色油漆标记，则该处为齿节圆跳动最大点，侧隙调整应在该处调整（图 3-1）。

Gear ring tooth surface has 3 max runout with green mark,drive pinion side backlash must be adjusted.

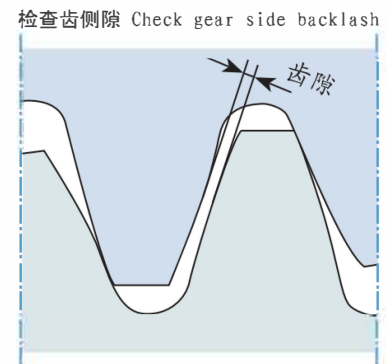

(图 3-1)

四、安装支架要求

Bracket requirements before mounting

1) 回转支承安装基面或安装平台必须清理干净，不允许有小碎杂物、焊渣、局部小凸点及锈蚀现象。

Slewing bearing mounting base level or mount platform must be clean without sundries,broken bits protruding point and corrosion.

2) 安装支架必须有足够的刚性、强度及耐冲击性能，防止回转支承使用时变形，影响其回转精度。

Mounting bracket must be with rigidity,intensity and impact resistance to avoid bearing distortion that influences slewing precision.

3) 采用筒形的焊接支架，为防止支架变形，焊后应进行消除内应力处理，再进行机械加工。对于不易进行机械加工的平面，可以采取垫平法进行安装（图 4-1B）。

Adopting canister shape welding bracket to avoid bracket distortion,after welding to treat remove inner stress treatment the mechanize,you can see Drawings 5-1 A.For uneasy to mechanize mounting plane,can level up to mount(Picture 4-1B)

4) 支架螺栓孔应与转盘安装孔对应，避免安装干涉引发转盘变形（图 4-1C）。

Bracket bolt hole is the identical with slewing bearing mounting hole to avoid mount distortion(Picture 4-1C).

5) 回转支承连接表面的技术要求（表 4-2），在 0° - 90° - 180° 环形面区域内，只允许有一处波峰达到该值；且其余偏差只允许逐步下降或上升，不许忽降忽升，以避免峰值负荷（图 4-3）。

Slewing bearing connecting surface skills as 5-1 table, in 0° - 90° - 180° loop area,only allow a wave crest up to the value,other warp allows down or up step by step,not allowed down or up suddenly to avoid peak value load.(Picture 4-3)



表 4-2: P0 级回转支承支承零件链接表面技术

Table4-2:P0 slewing bearing supporting parts connections

滚道直径 (mm) Raceway dia(mm)	平面度 Plane degree	圆周两相邻单位长度 (L = 1 个孔距) 上相同方向倾斜度 (s-t)mm Circle border upon unit (L=1 bore distance) same direction lean (s-t) mm	圆周两相邻单位长度 (L = 1 个孔距) 上相同方向倾斜度 量变化 (s+t)mm Circle border upon unit (L=1 bore distance) same direction lean (s-t) mm	径向宽度 b 的倾斜度 δ radial width b lean δ (mm)	端面粗糙度 Ra side-face roughness Ra (mm)
630~1000	0.2	0.0002L	0.0002L	0.10	2.5
1000~1600	0.25	0.0002L	0.0002L	0.12	3.2
1600~2500	0.3	0.0002L	0.0002L	0.15	3.2
2500~4000	0.4	0.0002L	0.0002L	0.20	3.2
4000~6300	0.5	0.0002L	0.0002L	0.25	3.2



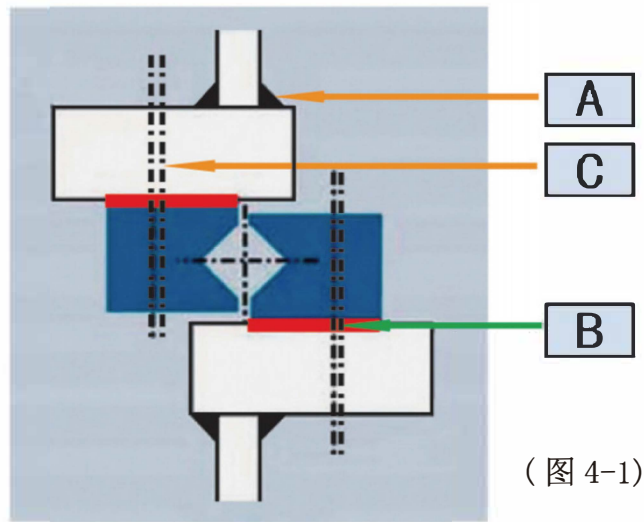
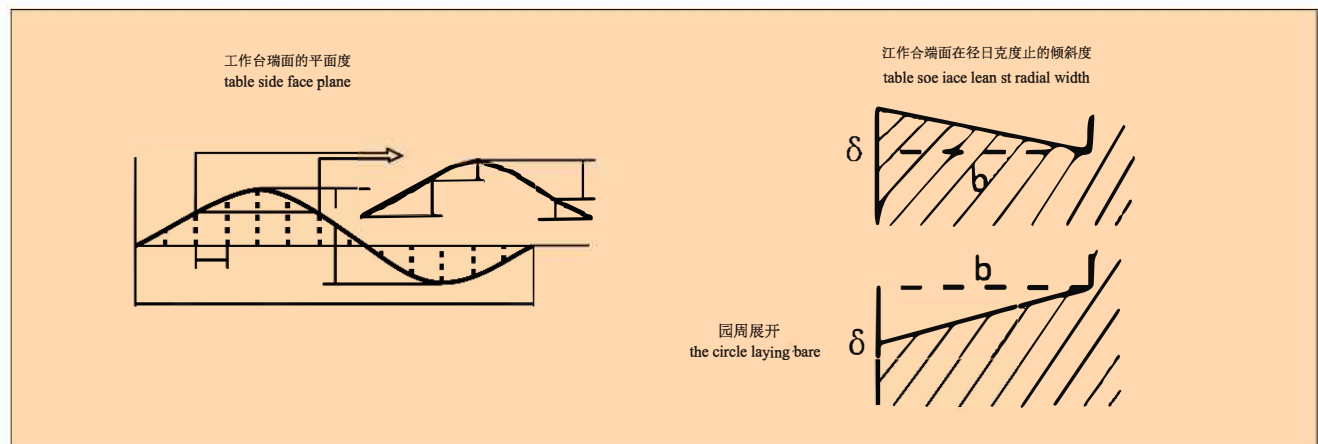
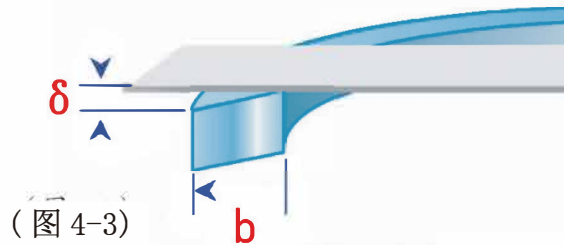

五、安装要求

Mounting requirements

1) 检查与轴承配合的相关零件的尺寸及加工精度。产品零部件（包括外购、外协件）应具有检验合格证方能进行装配。

Check relative parts sizes and process precision, Product parts (including outsourcing, cooperation part) must have inspection certificate before assembly.

2) 用修配法装配的零件，修整后的主要配合尺寸必须符合设计要求或工艺规定。

Parts assembled by the repair method, main size must fit for design requirements or technical regulations.

3) 装配环境必须清洁，与轴承相关的零件在装配前应清理和清洗干净，不得有毛刺、飞边、氧化皮、锈蚀、切屑、砂粒、灰尘和油污等，并应符合相应清洁度要求。

Assembling environments must be clean, relative parts with bearings must clean up, without burr, oxidation skin, corrosion bits, grains, dust, oil dirt etc before assembly, should comply with clean requirements.

4) 装配过程中轴承及零件应防止磕碰、划伤和锈蚀。

bearing and parts can not be knocked, scratch and corrosion during assembly.

5) 不允许用锤直接敲击回转支承，不允许通过滚动体传递安装冲击力，应使用合理专用工具、吊具安装轴承。

Not allow hammer to hit slewing bearings, not allow to transfer mounting wallop through rolling elements, mounting bearings by proper tools, hanges.

6) 将回转支承水平吊放在支承座上以后，用塞尺检测轴承平面与支承座平面的接触情况，如有间隙可以采用机械加工修平或用局部垫平法消除间隙，以防止螺栓拧紧后轴承变形，影响回转支承正常旋转。

(图 5-1)

After the slewing bearing is hoisted on the mounting base horizontally, insert ruler to check bearing plane with supporting housing connection, in case gap to mechanize to repair or level up to avoid bolts screw down to distortion that influence slewing bearing rotation regularly (Picture 5-1).

7) 安装时淬火软带“S”处应置于非负荷区或非经常负荷区，（装填塞滚动体塞子部位总是位于套圈的软带处）。（图 5-2）

Quenching “S” soft zone locating non-load or seldom load area while mounting quenching soft zone, (plug is around soft one on ring). (Picture 5-2).

8) 齿侧隙的检查，为了确保齿轮啮合精度，在组装过程中应保证适当的齿侧隙。在工作过程中，确保大齿圈齿节圆跳动的最高点（三个涂有绿色标记齿）处的啮合侧隙符合设计精度的要求。（图 5-3）

Checking backlash to insure gear meshing accuracy and keep proper backlash while mounting. During operation, ensure that the meshing backlash at the highest point of the pitch circle runout of the large gear ring (3 painting green marks teeth) meets the requirements of design accuracy. (Picture 5-3).

9) 安装时回转支承应采用高强度螺栓连接，并根据回转支承受力情况，选择合适的强度等级，螺栓的规格和强度等级按 GB5782、GB5783 和 GB3098.1 标准选取，螺母的强度等级按 GB3098.2 标准选取。

Adopt high strength bolts while mounting, according slewing bearing press condition to select intension class, bolts sizes and strength class standard GB5782, GB5783&GB3098.1, nut strength class are selected to standard GB3098.2.

10) 安装螺栓垫片应采用调质平垫片，严禁使用弹簧垫圈。

Bolts washer to be used quenching & tempering washer, spring washer are strictly prohibited.

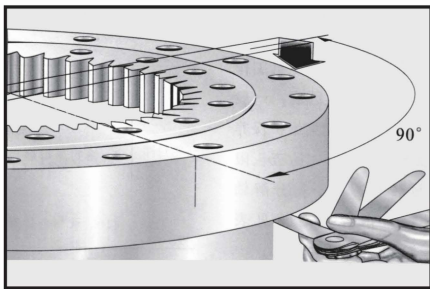

(图 5-1)

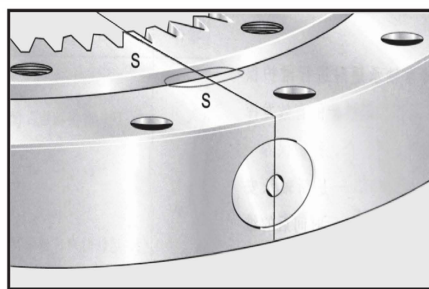

(图 5-2)

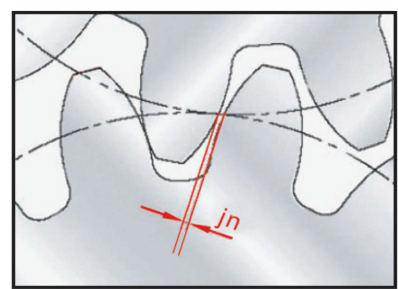

(图 5-3)

11) 当径向负荷超过轴向负荷的 10% 时，回转支承应有径向定位，回转支承径向定位后，应用力矩扳手分低、中、高三次预紧，并按交叉 180° 方向对称拧紧顺序有步骤进行（图 5-5），确保最后一遍螺栓有相同的预紧力，同时检查轴承的回转是否灵活（图 5-4）。

When radial load > 10% axial load, slewing bearing need radial orientation, after radial orientation, moment wrench has the same pre-press by low, mid, high pre-pressing, and cross 180° direction symmetry screw down (Picture 5-5) to insure the last bolts with the same pre-pressing, meantime check slewing bearing free rotation status (Picture 5-4).

12) 安装螺栓应有足够的预紧力，其预紧力为螺栓材料屈服极限的 0.7 倍，螺栓的屈服极限参照表 5-1：各种不同直径螺栓的预紧负荷参照表 5-2：

Mount bolts with enough pre-pressing, pre-press is 0.7 times of bolts materials yield limits, bolts yield limits as table 5-1; different dia bolts pre-load see table 5-2:

表 5-1：螺栓的屈服极限

Table 5-1: bolts yield limits

螺栓强度等级 Bolts strength class	8.8	10.9	12.9
屈服极限 Yield limits MPa	M ≤ 16 640 M ≥ 16 660	940	1100

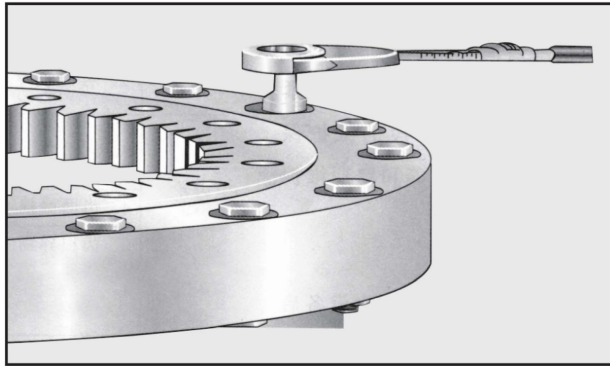

(图 5-4)

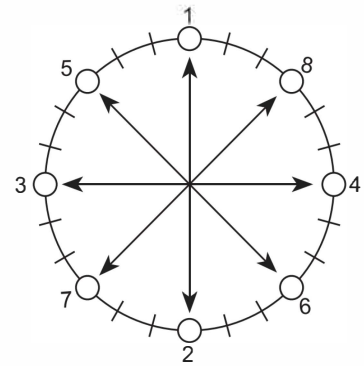

(图 5-5)

表 5-2: 不同直径螺栓的预紧负荷

Table6- 2:Different dia bolts pre-load

螺栓规格 Bolts specifications GB5782-86 GB5783-86	安装孔直径 (mm) Mount hole dia (mm)	螺栓强度等级 Bolts strength class(GB3098.1-82)		
		8. 8	10. 9	12. 9
		螺栓材料的强度极限 σ_{smin} (N/mm ²) Bolts materials strength limits σ_{smin} (N/mm ²)		
		640	900	1080
		预紧扭矩 MA (Nm)Pre-tighten torque MA (Nm)		
M12	13. 5	77. 5	110	130
M14	15. 5	120	170	210
M16	18	190	265	320
M18	20	260	365	435
M20	22	370	520	620
M22	24	500	700	840
M24	26	640	900	1080
M27	30	950	1350	1620
M30	33	1300	1800	2160
		预紧力 FA (10 ³ N)Pre-tightening force FA(10 ³ N)		
M33	36	293	412	495
M36	39	344	484	581
M39	42	414	581	698
M42	45	473	665	798
M45	48	553	777	932
M48	52	623	876	1050
M52	56	749	1054	1265
M56	62	863	1214	1457
M60	66	1008	1418	1621

六、安装后检验

Inspection after mounting

1) 回转支承调试前，应加注合适的润滑脂，边加注边缓慢运转，使润滑脂均布。

1) Before debugging slewing bearings, should fill in proper grease, move slowly while filling to make grease equally spaced.

2) 确认安装没有对回转支承产生变形影响，禁止在回转支承附近搭接地线，焊接回转支承和其它部件。

2) Make sure not effect bearing distortion while mounting, not allowed grounding line to weld slewing bearings and parts.

3) 所有螺栓拧紧后旋转轴承 5 周以上，检查回转支承旋转是否灵活，是否与其它零部件有干涉现象，密封圈是否完好，是否有异常响声。旋转后，重新检测齿侧间隙值，请将这些数值记录下来。(图 6-1)

3) After all bolts are tightened, rotate the bearing more than 5 circles, and check whether the slewing bearing rotates flexibly and interferes with other parts, whether sealing good, whether have abnormal ringing. After rotation, anew to check backlash data and take a note. (Picture 6-1).

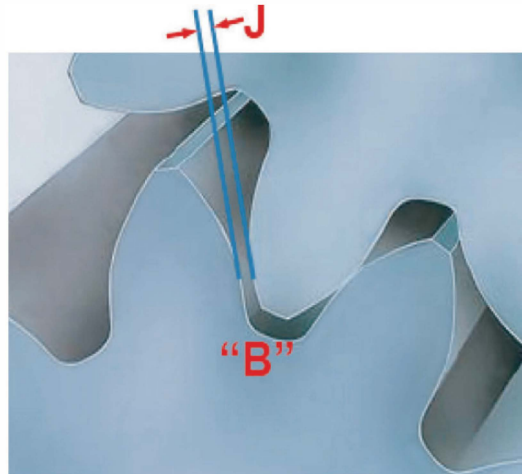

(图 6-1)

七、使用保养

Application and Maintenance

1) 安装螺栓和异常现象的检查

轴承在运转约 100 小时后，检查内、外圈安装螺栓的预紧力距是否满足规定值，以后，每运转 500 小时检查一次。

1) Inspection of mounting bolts an abnormal appearance

After bearing rotation 100 hours, check pre-tighten torque of inner ring and out ring, then once 500 hours inspection.

2) 使用时若出现噪音、冲击、电流突然增大等异常现象，应停机检查，排除故障，必要时应拆检。

2) If coming noise, impact, electric current increasing suddenly in application, stop machine to disport and get rid of trouble, if necessary, inspect by removing.

3) 轴承在安装以后, 应填充专用润滑脂, 如需要可以向制造厂询问, 在填充润滑脂时, 应边填充边转动轴承, 使润滑脂均匀分布直到新的油脂开始挤出密封唇为止。以后间隔 100 小时充填一次, 在较高环境温度和灰尘多的情况下加油周期应缩短一些。机器长期停止运转的前后也必须加足新的润滑脂。

3) After mounting bearings,fill in dedicating grease as user's requirements.if necessary to ask the maker,filling grease while rotation,grease equally spaced until grease spills over sealing lips.Once 100 hours filling later,filling grease period should be short at high temperature and dusty condition.

4) 齿面应每 10 天清除杂物一次, 并涂以润滑脂。对于轴承的齿面润滑, 因综合工作因素较多, 用户可根据具体要求自行选择最佳润滑脂, 推荐的润滑脂见表 (7-1)。

4) Gear surface should clear sundries every 10 days and bearing gear lubrication,User can personally select the finest grease due to combined working elements.Recommendatory grease as table 7-1.

5) 使用中防止回转支承受阳光直接暴晒雨淋, 禁止用水直接冲刷轴承, 以防水进入滚道, 严防较硬异物接近或进入齿啮合区。

5) Avoid direct sunlight on slewing bearings while usage,can not directly wash bearing with water to avoid water into raceway,avoid hard forcibly eye-winker access or ingress tooth meshing area.

6) 定期查看密封的完好情况, 如果发现密封圈老化、破损应及时更换, 如发现脱落应及时复位。

6)Often check sealing,in case seals aging,damaged,change seals timely,In case fall off,reposition timely.

表 7-1:

Table7-1:

环境条件 Circumstance condition	润滑部位 Lubrication position	润滑脂 Lubrication	
		牌号 Trademark	标准号 Standard
低温 -20℃ ~60℃ Low temperature -20° C ~60℃ 潮湿 wet	滚道 Raceway	1# 或 2# 极压锂基脂 1#or2#pole lithium grease	GB7323-1994
	齿轮 Gear	ZG-S 石墨基润滑 Graphite base grease	SH/T0369-1992
高温 40℃ ~120℃ High temperature 40' C ~120℃ 潮湿 wet	滚道 Raceway	1# 或 2# 极压锂基脂 1#or2#pole lithium grease 3#MoS2 复合钙基脂 3#MoS2Composed Ca base grease	GB7323-1994
	齿轮 Gear	4# 高温润滑脂 4#High temperature lubrication	SH/T0376-1992
常温 ~50℃、耐海水腐蚀	滚道 Raceway	2# 铝基脂 2#Al base grease	SH/T0378-1992
	齿轮 Gear	2# 铝基脂 2#Al base grease	SH/T0378-1992

■ 恒久专注 冠军品质

应用领域 Application field



盾构机
Shield machine



钢包回转台
Ladle turret



斗轮堆取料机
Bucket wheel stacker reclaimer

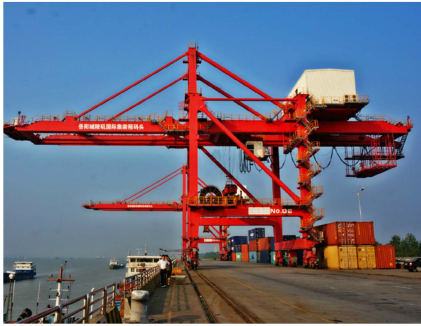

卸船机
Ship unloader



克令吊
Deck crane



定日跟踪系统
Solar energy

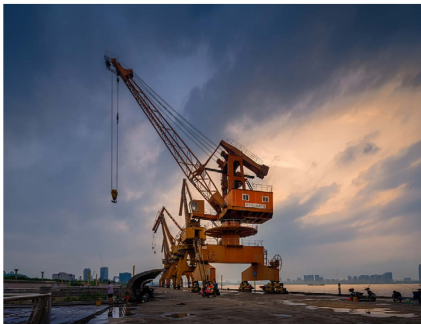

港口起重机
Port crane



挖掘机
Excavator



摩天轮
Ferris wheel



风力发电
Wind power generation



工业CT机
Industrial CT machine



海洋平台起重机
Offshore platform

选型信息表 Model Selection Information Table						
主机名称 Main machine				主机型号 Machine model		
工 况 Working condition		轴向载荷 (KN) Axial load	径向载荷 (KN) Radial load	倾覆力矩 (KN.m) Overturning moment	转速 (rpm) Speed	工作时间 (%) Working time
载 荷 Load	静态 Static 最大: Max					
	试验: Test:					
					
	动态 Dynamic 最大: Max:					
	试验: Test					
	超载: Overload					
					
	振动, 冲击程度 Vibration impact	轻度 Light		中度 Medium	重度 Heavy	
使 用 Use	使用寿命 (h) Service life					
	安装方式 Installation method	水平: 座式, 挂式 Horizontal: seat type, hang type		垂直: Vertical	其它: Other	
	使用方式 Usage mode	连续: Continuous	间歇: Intermittence	摆动: Swing	其它: Other	
	旋转零件 Rotating parts	外圈: Outer ring		内圈: Inner ring		
	润滑方式 Lubrication method	脂: Grease	油: Oil	其它: Other		
	密封 Seal	主机设置: Main machine setting		轴承设置: Bearing setting		
	轴承驱动圆周力 Bearing driving circumferential force					N
	环境条件 Environment condition	湿度 (%): Humidity		温度 (°C): Temperature	污染: Pollution	
	轴承工作温度 Bearing operating temperature					°C

洛阳恒昌重工有限公司

Luoyang Hengchang Heavy Machinery CO.,Ltd

营销总部：洛阳市国家大学科技园 A 区 4 号楼 507

工厂地址：洛阳市涧西区西马沟工业园

电话：13837962060(同微信)

网址：[https:// www.hgbearing.net/](https://www.hgbearing.net/)

邮箱：cindy@hgb-bearing.com

Sales Add:507, Building 4, Zone A, National University
Science Park, Luoyang

Factory Add: Ximagou Industrial Park, Jianxi District,
Luoyang, Henan, China

MB: +86 13837962060(Wechat/Whatsapp)

Website: [https:// www.hgbearing.net/](https://www.hgbearing.net/)

Mailbox: cindy@hgb-bearing.com (Overseas)